

SERIE 229

ADVANCED TECHNOLOGY

MEMORY DIAL

EXPLOSION PROOF

WEATHERPROOF

VANDAL PROOF



REMOTE
DIAGNOSTIC
REINFORCED
COMPOSITE
FLASHING
LIGHT

OPTIONAL EQUIPMENT
*VOIP EQUIPMENT
*HEADSET EQUIPMENT



HANDS FREE



www.lelas.fr
+33 (0)1 48 76 62 62

LELAS
GROUPE



DESCRIPTION

Explosion-proof EEx IP66 telephone for wall mounting, indoor and outdoor, for industrial and noisy environments.

- **Electrical Characteristics:**
 - Direct current supply: 12 to 60 Vdc
 - Consumption: 15 to 45 mA
 - Ringing voltage: 30-90 Vac
 - Dialling: DTMF/PD
 - Flashing: adjustable
 - Electronic Bell: 84 to 92 dB at 1 m subject to model
 - Flashing beacon: option
 - Noise cancelling: noise cancelling circuit
 - Hook: magnetic
 - Conversation Mode: by handset/Hands free/Headphone
 - Other characteristics: CCITT Q23
- **Options**
 - IP box
 - Remote diagnostics
 - Headphone
 - Second receiver
 - Handset cord 1m70

■ **Overall dimensions**

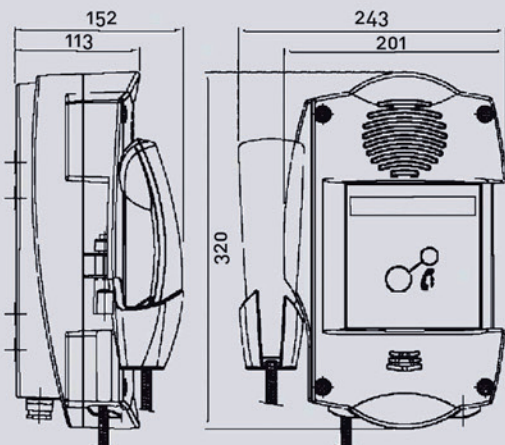

Group LELAS, founded in 1909, has created a new range of high quality telephones reflecting these major principles: safety of communication, sound optimisation, and integration of latest technological achievements within its products.

Low energy consumption with maximum power, a receiver adaptable to different environments, a hands-free version, a high degree of watertight protection and high shock resistance, optional IP version, parts easily removed for maintenance purposes and different options offered by LELAS make the most demanding customers choose this explosion-proof telephone 229.

LELAS users benefit from the company's 100 years of experience of creating robust and safe telecommunication systems. New telephone model 229 is easy to install and to connect to the telephone line, has a wide choice of options, robust weatherproof and explosion-proof components which can be used in the harshest climatic conditions, stainless steel screws, made of reinforced polycarbonate to resist shocks, keyboard version, LCD display, call memory, integrated flashing beacon, remote testing by master station.

All LELAS equipment has a 3 year guarantee for maintenance and spare parts.

CHARACTERISTICS

- Body material / color: polyester plastic / RAL2003
- Handset material / color: polyester plastic / black
- Handset cord: stainless steel 100 kg resistance
- Loudspeaker (hands-free)/microphone: vandal resistant / 5W > 78 db at 1 m
- Mounting: on wall (2 or 4 fixing holes)
- Termination: inside screw connections
- Dimensions: 201 x 320 x 113 mm
- Weight: 2.4 kg
- IP-rating: IP66
- Impact rating (IK): 10
- EEx protection: EEx em [ib] ib IIC T5 / ATEX II 2 G D
- Max. / min. amb. temp: -40 °C / + 60°C
- Maintenance: all circuits and control devices are fixed on the easily removable front plate for a very quick substitution of equipment in the field.

REFERENCES

Model*	Handset	Hands-free	Display	Keyboard & Memory	1 button	Flashing beacon	Remote diagnostics
TLC229A1	●						●
TLA229A1	●			●			●
TLS229A1C9G	●	●		●			●
TLS229A1C9FGL	●	●	●	●		●	●
TLS229A1C9FL	●	●	●	●		●	●
TLS229A1B		●			●		●

*For Zone 2 Range 237 instead of 229; Also version A2 for -20°C / + 60°C temperature.

