

TELEPHONES LE LAS (FRANCE Head Office)

Tel:0033 1 48766262

E-mail: lelas@lelas.fr

Fax:0033 1 48768304

Website : www.lelas.fr

All screws are stainless-steel only

VoIP Explosion proof IP66
Hands free type, duplex / push-to-talk
Wall mounting, keypad
NHA214HC9LM

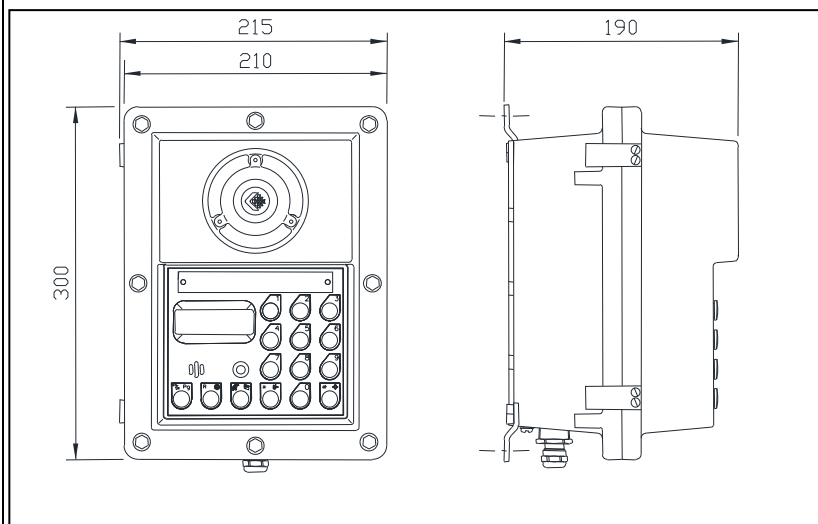

Electrical Characteristics:

Direct current supply : POE
Conversation mode : hands-free, duplex,
push-to-talk

Explosion proof marking :

Specific marking : II2G (gas) or Ex II2GD (dust)
Additional marking : Ex dIIBT6Gb / II2G
Ex tb IIIC / T°85C Db

Material/Color : cast aluminium / RAL2003
Microphone : vandal resistant/weatherproof type
Loudspeaker : resistant/Weatherproof type 15W
Mounting: wall mounting with 3 points
Dimension : 210 X 320 X 190 mm
Weight : 8,6 kg
IP-rating : IP66
Max. / min. amb. Temp : -40 °C / + 60°C

VOIP Characteristics:

Voice and Media Middleware

- Certified SIP Signalling Stack
- Feature Rich Telephony Application
- SIP, RTP, RTCP, STUN, NTP
- Stand Alone P2P and Proxy Infrastructure Modes
- SIP Failover Server Support
- Analog Audio Subsystem
- Consilient Voice Processing Subsystem

Telephony Features

- Hotline, Intercom, Push-to-Call Modes

Consilient Voice Processing Subsystem

- G.711a, G.711u, G.736-32, G721-RFC3551, iLBC, G.722
- AEC (Acoustic Echo Canceller)
- DTMF Detect and Generate
- Call Progress Tones

webUI Module

- Complete Web Interface for Configuration
- Login Authentification

