

## Model 371LED-120

Commander® Rotating Light

2562671 Rev A3 1223



**Limited Warranty:** This product's limited warranty can be found at [www.fedsig.com/SSG-Warranty](http://www.fedsig.com/SSG-Warranty).

### SAFETY MESSAGES TO INSTALLERS AND USERS

It is important to follow all instructions shipped with this product. This device is to be installed by a trained electrician who is thoroughly familiar with the National Electrical Code and/or Canadian Electrical Code and will follow the NEC and/or CEC Guidelines as well as all local codes. This light should be considered a part of the warning system and not the entire warning system.

The selection of the mounting location for the light and its controls and the routing of the wiring are to be accomplished under the direction of the facilities engineer and the safety engineer. Listed below are some other important safety instructions and precautions you should follow:

- Read and understand all instructions before installing or operating this light.
- Do not connect this light to the system when power is on.
- After installation, make sure that all set screws and threaded joints are properly tightened.
- To be an effective warning device, this product produces bright light that can be hazardous to your eyesight when viewed at a close range. Do not stare directly into this lighting product at a close range, or permanent damage to your eyesight may occur.
- After installation, test the light to make sure that it is operating properly.
- Establish a procedure to routinely check the light for proper activation and operation.

Failure to follow all safety precautions and instructions may result in property damage, serious injury, or death to you or others.

**OVERVIEW** – The Federal Signal Model 371LED-120 warning light incorporates an array of high power LEDs, a custom optic, and a rotating reflector to focus a beam of light that rotates 360 degrees within a plastic dome.

The Model 371LED-120 features an impact-resistant

plastic dome. The Model 371LED is available in five colors: amber, blue, clear, green, and red. The dome-and-ring assembly screws on, providing access to the interior of the light. The base features textured black powder paint for greater corrosion resistance. Wiring can be routed through the pipe-mount opening in the bottom of the light, or the two side knockouts can be used for side entry wiring. Installation can be surface or 1" NPT pipe mount.

An optional accessory reflector (Model 371LED-KIT-CR) is available that reflects the light beam at 22.5 degrees from the vertical orientation for overhead mounting and other applications. See Figure 1.

**Figure 1 Beam with 22.5° and 90° reflectors**

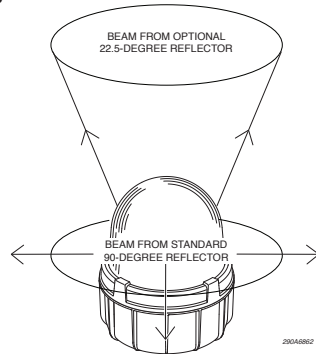

An optional wall mount bracket is also available. The LHWB wall mount bracket can be used to mount the Model 371LED. For surface mounting on solid substrates, the separately purchased Model 371BRCKT three-point surface mount bracket is available.

**Table 1 Electrical and environmental ratings**

Operational Voltage	120 Vac 50 Hz/60 Hz
Flash Rate	60 FPM
Maximum Operating Current, mA	320 mA
In-rush Current	25.1 A for 0.63 ms
Operating Temperature	-31°F to 104°F (-35°C to 40°C)
Environmental Ratings	Type 4X, IP66, IP69 Compliant

**Table 2 Dimensions**

Height	11.38 in (288.9 mm)
Diameter	9.12 in (231.6 mm)
Net Weight	7.1 lb (3.2 kg)
Shipping Weight	8.1 lb (3.7 kg)

**Unpacking the Device** – After unpacking the device, examine it for damage and verify the parts. If a part is missing or damaged, do not attempt to install the device. Contact Federal Signal Customer Support.

## Installation

The Model 371LED-120 light is designed for mounting on a flat horizontal surface or on a 1" NPT pipe. For surface mounting on solid substrates, the separately purchased Model 371BRCKT surface mounting bracket can be used. If conduit side entries are to be used, disassemble the light as described in the "Wiring the Light" section and remove one or more knockouts with a blunt tool before mounting the light. Use a file to remove excess flash around the knockout.

**NOTE:** To avoid moisture buildup within the light enclosure in highly humid areas where condensation is present in the conduit system, duct sealant or other suitable materials are recommended for sealing the wires/conduit entrances.

### Pipe Mounting the Light

Attach the light to the 1" NPT pipe by threading the light clockwise on the pipe. See Figure 1. After mounting, wire the device per Figure 2.

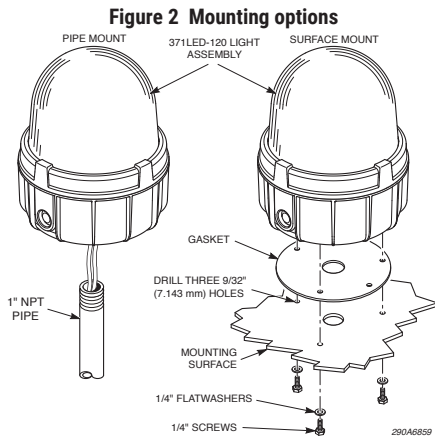

### Surface mounting the light

To mount the light on a flat surface:

- Using the gasket as a template, scribe four drill-position marks on the mounting surface. See Figure 1.

- Drill a 9/32" (7.1 mm) diameter hole at each of the outside drill-position marks for mounting.
- Drill or punch a 1-3/8" (34.9 mm) diameter hole at the center drill-position mark for the wire entry.
- Attach a suitable 1" NPT hub or connector to the conduit entrance in the bottom of the light. For Type 4X/IP66 applications, the hub or connector must be suitably rated. (Myers® STTTB-2 or T&B® H100-TB hubs are recommended.)
- Set the light on the gasket and attach it to the mounting surface with the provided 1/4" screws and washers.
- After mounting, wire the device per Figure 2.

### Installing the Optional 22.5° Reflector (Model 371LED-KIT-CR)

The light is shipped from the factory with the standard reflector that creates a horizontal lightbeam that is 90 degrees from the vertical orientation. An optional reflector is available that reflects the light beam at 22.5 degrees from the vertical orientation.

To replace the standard reflector with the 22.5-degree reflector:

- Disconnect power to the light.
- Remove the dome assembly by grasping the diecast ring attached to the dome and turning it counter-clockwise. See Figure 3.

**Figure 3 Installing the 22.5° reflector**

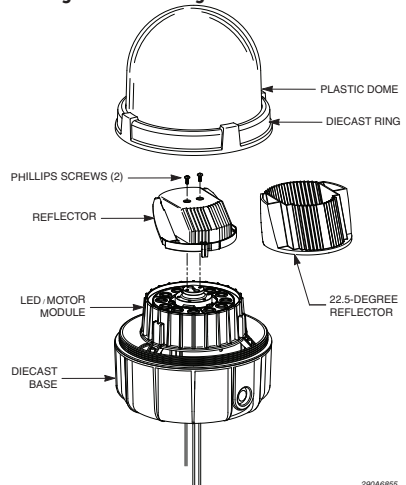

- Loosen the two Phillips screws that retain the reflector.
- Gently lift the reflector from the assembly while being careful to not drop the two screws.

5. Position the new reflector onto the assembly and secure it with the two screws.
6. Reinstall the dome assembly.
7. Reinstall power and test the light for proper operation.

## Wiring the Light

**Figure 4 Connecting leads to the terminal block**

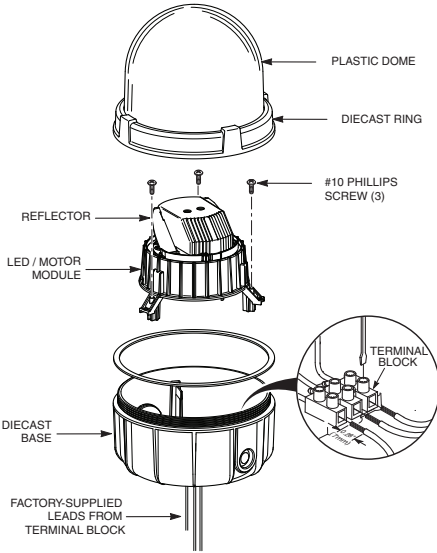

### **⚠ WARNING**

**SHOCK HAZARD: To avoid electrical shock, do not connect wires while power is applied.**

The Model 371LED comes assembled from the factory with two color-coded leads for wiring to a junction box. If desired, the factory leads can be removed and the supply connections can be directly made to the terminal block located on the bottom of the light base as described below.

1. Remove the dome assembly by grasping the diecast ring attached to the dome and turning it counterclockwise.
2. Remove the three #10 Phillips® screws that secure the LED / motor module to the housing.
3. Remove the LED / motor module.
4. If preferred, remove the factory-supplied leads from the terminal block.
5. If you are using conduit side entries, attach a Myers® STTTB-2 or a T&B® H075TBH 3/4" NPT conduit hub with a 3/4" NPT close nipple (both installer-supplied) to the housing and securely

tighten the hub. When side entries are used, the bottom 1" NPT conduit entry must be plugged with a threaded plug (installer-supplied). See Table 4

6. Route the supply wires (10 AWG to 16 AWG) into the light housing.
7. Strip a maximum of 0.28" (7 mm) of insulation from the ends of the power leads. Connect the wires to the terminal block by inserting the stripped ends of the wires into the connectors as far as they can travel.
8. Tighten the clamping screw. The maximum tightening torque is 7.0 in-lb (0.8 Nm).
9. Connect the earth ground to the terminal block.
10. Reassemble the light and test it for proper operation.

### **SAFETY MESSAGES TO MAINTENANCE PERSONNEL ⚠**

Listed below are some important safety instructions and precautions you should follow:

- Read and understand all instructions before operating this system.
- Any maintenance to the light system must be done with the power turned off.
- Any maintenance to the light system must be performed by a trained electrician in accordance with NEC/CEC Guidelines and local codes.
- Never alter the unit in any manner. Safety might be compromised if additional openings or other alterations are made to units.
- The nameplate, which contains cautionary or other information of importance to maintenance personnel, should not be obscured.
- If the dome is damaged in any way, the complete dome assembly **MUST** be replaced.
- After performing any maintenance, test the light system to ensure that it is operating properly.

Failure to follow all safety precautions and instructions may result in property damage, serious injury, or death.

## Maintaining the Model 371LED-120

Establishing a regular maintenance schedule for the Model 371LED-120 extends the life of the light and ensures safety. Periodically verify that the light operates properly. Inspect the dome for cracks, crazing (hairline cracks), discoloration, and other defects.

The threaded dome ring joint should be well lubricated with petroleum or a soap-thickened mineral oil. If corrosive products have accumulated on the joints and cannot readily be removed with solvents, discard and replace the parts.

## Cleaning the Dome

Maintenance procedures sometimes require fixtures to be hosed down for good housekeeping. The electrical circuit should be turned off prior to hosing down the light.

Clean the dome periodically to maintain maximum light output. Use only mild, non-abrasive cleaning agents.

## Maintenance and Service

**Technical Assistance:** Contact our Technical Support Team at +1 708-587-3587 or [signalsupport@fedsig.com](mailto:signalsupport@fedsig.com).

**Repair Service:** A return authorization is required. Contact your Authorized Distributor or Federal Signal Customer Support. Defective products under warranty will be repaired or replaced at Federal Signal's discretion.

**Product Returns:** Returns require authorization from Federal Signal. Contact your Authorized Distributor for more information on our return policy or to request a return.

## Ordering Replacement Parts

Consult the product datasheet online for an updated list of replacement parts. If the product requires a part that is not available for purchase, your unit must be repaired or replaced. The product's dome should be regularly inspected for scratches or chips and if damaged, it must be replaced. A strap wrench (6" capacity) may be used to aid in the dome removal.

Table 3 Replacement parts

Description	Part Number
Plastic Dome Assembly, Amber	K8459125
Plastic Dome Assembly, Blue	K8459125-01
Plastic Dome Assembly, Clear	K8459125-02
Plastic Dome Assembly, Green	K8459125-03
Plastic Dome Assembly, Red	K8459125-04
Gasket, Surface Mount	K8459127
LED / Motor Module, Amber	K8459159-A
LED / Motor Module, Blue	K8459159-B
LED / Motor Module, White	K8459159-W
LED / Motor Module, Green	K8459159-G
LED / Motor Module, Red	K8459159-R

Table 4 Accessories

Description	Part Number
Wall-Mount Bracket	LWMB2
Corner-Mount Bracket	LCMB2
Mounting Bracket, Surface	371BRCKT
Conduit Hub Kit, 3/4" NPT	K8459138
Close-Up Plug, 1" NPT	K8459130
22.5 Degree Reflector	371LED-KIT-CR



## FEDERAL SIGNAL Safety and Security Systems

2645 Federal Signal Drive, University Park, Illinois 60484

Additional translations available at [signaling.fedsig.com](http://signaling.fedsig.com)

Traducciones adicionales disponibles en [signaling.fedsig.com](http://signaling.fedsig.com)

Customer Support 1-800-344-4634+1-708-534-4756, [iordersup@fedsig.com](mailto:iordersup@fedsig.com)

Technical Support 1-800-755-7621+1-708-587-3587, [signalsupport@fedsig.com](mailto:signalsupport@fedsig.com)

[signaling.fedsig.com](http://signaling.fedsig.com)