

## Manual Call Point

Pushbutton and Break Glass Stations for Use in Hazardous Locations

25500424 Rev A4 0823



**Limited Warranty:** This product's limited warranty can be found at [www.fedsig.com/SSG-Warranty](http://www.fedsig.com/SSG-Warranty)


**SAFETY MESSAGES TO INSTALLERS AND USERS** ⚠️: Products should be installed by a licensed electrician and follow all safety instructions. Failure to do so may result in property damage, serious injury, or death.

- Read and understand all instructions before installing or operating this equipment.
- To avoid electrical shock hazards, do not connect wires when power is applied. Failure to observe this warning may lead to serious injury or death.
- Never alter the unit in any manner. Safety in hazardous locations may be endangered if additional openings or other alterations are made in units specifically designed for use in these locations.
- Do not connect this station to the system when power is on.
- After installation, ensure that all threaded joints are properly tightened.
- Keep the unit tightly closed when in operation.
- After installation, test the station and the system to ensure that it is operating properly.
- After testing is complete, provide a copy of this instruction sheet to all personnel.
- Establish a procedure to routinely check the station and system for proper activation and operation.

Failure to follow all safety precautions and instructions may result in property damage, serious injury, or death.

### Certifications

ATEX and IECEx Certification Information:

Certificate Nos.	ATEX Cert No.: DEMKO 19 ATEX 1939X IECEx Cert No.: IECEx UL 19.0074X
ATEX coding	 II 2 G D
Protection	II 2 G Ex db eb mb IIC T4 Gb (Tamb= -40°C to +70°C) CP-BG models: II 2 D Ex tb IIIC T100°C Db IP66 CP-PB models: II 2 D Ex tb IIIC T100°C Db IP65

EN60079-0, EN60079-1, EN60079-7, EN60079-18, EN60079-31, IEC60079-0, IEC 60079-1, IEC60079-7, IEC60079-18, IEC60079-31

Refer to Certificates for specific standard versions.

### Specific Conditions of Use

1. The equipment has an optional protective non-metallic cover that may provide a potential electrostatic charging hazard.

- The equipment has an optional metallic break glass hammer mounted to the enclosure, which can store electrical charge and therefore may provide a potential electrostatic charging hazard. The metallic break glass hammer has a capacitance of 94pF.
- These devices reach a temperature of 85°C at the entry point.

### Construction Products Regulation (CPR) Certification Information



- Model Designation: CP-BG-x-x-x-xxx-xx-x
- Description: Manual call point for fire detection and fire alarm systems for buildings.
- Declaration of Performance No.: 0843-CPR-1073, 2821-CPR-0207. (To access it: Go to [www.fedsig.com](http://www.fedsig.com), search model "CP-BG" to access product webpage, click "Resources" tab. The document is located under "Agency Certificates" section)
- Standard Applied: EN54-11:2001/A1:2005.
- Identification Number of Notified Product Certification Body: 2821 (CE), 0843 (UKCA).
- Manufacturer: Federal Signal, 2645 Federal Signal Drive, University Park, IL 60484
- EU Auth. Rep: FS VAMA, Doctor Ferran 7, 08339 Vilassar de Dalt, Spain. UK Auth. Rep: Victor Products, Unit 3A, Tyne Dock East Side, Port of Tyne, South Shields, NE33 55Q, ENGLAND.
- Marking Year for CE and UKCA: 2022

### Conditions for Safe Use

- This device has been tested for a voltage range of  $\pm 10\%$ .
- Do not install Test Reset Key. Key may only be installed for applications not requiring EN54-11 certification.
- To enable correct installation and operation, review all sections in this manual #25500424A for all technical, installation, and maintenance data.

### UL-C-UL Signaling Certification Information (Model CP-PB Series)

- UL Certification applies to push button models series CP-PB Series only. CP-BG models are not UL/C-UL Listed.
- For use in Non Monitoring (NM) and Self Monitoring (SM) Emergency Signaling Applications.
- Not for use with Fire Alarm or Fire EVAC Applications. Product can not be marked "FIRE" or "EVAC."
- Ambient temperature rating: -40°C to +60°C.
- Input Ratings: 48 Vdc, 3 A (max).
- This product is not provided with a preassembled conduit hub. A Listed hub shall be used and shall be connected to the conduit before the hub is connected to the enclosure.
- Only the models with suffix "5" (No Red color and with tactile marking - see nomenclature below) can be used in public emergency alarm reporting systems and emergency communications systems (ECS) in accordance with NFPA 72.

**Table 1 Callpoints Model Designation**

Prod Family	Activation	Entries	Color	Switch/Wiring Term	Left Flap/Hammer	Indicator LED	Certification
CP-	PB: Push Button	M: Metric N: NPT	Y: Yellow K: Black G: Green B: Blue R: Red	S: Single, Clamp term D: Dual, Clamp term 1: Single, Screw term 2: Dual, Screw term	NNN: None FNN: +Flap, No label no hammer FAN: +Flap, + Activate label, No hammer	00: None	4: UL 5: UL w/NFPA72 tactile markings (NO RED COLOR OPTION ALLOWED)

## ULand ULC Fire Alarm Certification Information (Model CP-PB and CP-BG Series)

1. UL and ULC Listed as a Non-coded, Manual Call Point. Refer to Tables 2 and 3 for model designations.
2. Do not install the Test Reset Key. The Key may be installed only for applications that do not require UL and ULC Fire Alarm certifications.
3. Environmental rating: US: Outdoor, Canada: Indoor Damp.
4. Ambient temperature rating: US: -35°C to +66°C, Canada: 0°C to +50°C.
5. Input Ratings: Regulated 24VDC (16 - 33VDC), 3 A (max).
6. This product is not provided with a preassembled conduit hub. A Listed hub shall be used and shall be connected to the conduit before the hub is connected to the enclosure.

**Table 2 CP-BG Series Call Points Model Designation**

Prod Family	Activation	Entries	Color	Switch/Wiring Term	Lift Flap/Hammer	LED	Cert.
CP	BG - Break Glass	M - Metric N - NPT	Red	S - Single, Clamp term D - Dual, Clamp term 1 - Single, Screw term 2 - Dual, Screw term	NFH - No flap, Fire label, Hammer NFN - No flap, Fire label, No hammer FFH - Flap, Fire label, Hammer FFN - Flap, Fire label, No hammer	00 - None	3 - UL Fire

**Table 3 CP-PB Series Call Points Model Designation**

Prod Family	Activation	Entries	Color	Switch/Wiring Term	Lift Flap/Hammer	LED	Cert.
CP	PB - Push Button	M - Metric N - NPT	Red	S - Single, Clamp term D - Dual, Clamp term 1 - Single, Screw term 2 - Dual, Screw term	NFN - No flap, Fire label FFN - Flap, Fire label	00 - None	3 - UL Fire

## UL/C-UL Hazloc Zones Certification Information

1. Zones Protection Ratings:  
Class I, Zone 1, AEx db eb mb IIC T4 Gb  
Ex db eb mb IIC T4 Gb  
Zone 21, AEx tb IIIC T100°C Db  
Ex tb IIIC T100°C Db  
(Tamb= -40°C to +60°C)
2. Class and Division Hazardous (classified) Location Ratings:  
Class I, Division 2, Groups A, B, C and D (T4).
3. Input Ratings: 48 Vdc, 3A (max).
4. **WARNING – Do not open when energized or within an explosive or dust atmosphere.**
5. **WARNING – Potential electrostatic charging hazard. The equipment may contain an optional protective non-metallic cover, which may provide a potential electrostatic charging hazard. Mitigation should be taken by the end user, using local Explosive Atmosphere (Ex) Electrical installations design, selection, inspection, and maintenance Codes and Standards.**

## Model Descriptions and Accessories

Federal Signal Manual Call Points Stations are available in two base models (PB – Push Button and BG – Break Glass), both providing the following standard and field customizable features:

- High-impact resistant glass-reinforced polyester (GRP) thermoset plastic housing and faceplate for corrosion resistance
- -40°C to 70°C ambient operational coverage
- Static-dissipative GRP housings and faceplates

- One or two switches available
- Three M20 or 1/2-inch NPT threaded entryways
- 180° rotatable rear housing with respect to front housing for top or bottom dual conduit feeds, with a single left or right feed.
- Color-coded front replaceable faceplate (red, yellow, green, blue, black)
- Front face visual status indicator (the white triangles)
- Reset keyway that may be installed on unit or used separately

**NOTE:** CP-BG-x-x-x-xxx-xx-2 (EN 54-11) models will NOT have the keyway installed in actual applications; it is only to be used separately as a discrete keyway and will be included separately as such.

- Removable internal wiring block/mounting plate for wiring ease, if desired
- Input wiring block types available:
  - 9-position cage-clamp design, or a
  - 9-position screw-down design
- Faceplate labels:
  - Eight adhesive-backed labels are supplied for field installation: FIRE, EVAC, BIOHAZARD, GAS, EMERGENCY, SHUTDOWN, LOCKDOWN, and Evac Logo (white or black on clear background)
  - Stainless steel faceplate labels are available as an option (separate service part # for field installation) for FIRE, EVAC, GAS ALARM, or BIOHAZARD ALARM (black text on stainless steel background)
  - Special applications (e.g., language, specific artwork, site location, etc.): The faceplate's labeling surface will accept user-supplied Uline 1.75-inch by 1/2-inch weather resistant labels for laser printers, Uline part # S-19297.
  - Custom stainless steel Duty Label (separate service part # for field installation): Side mounted on either PB or BG units (except BG units that have a break glass hammer bar already installed). Consult the factory for lead times, as this is a customized part for user-specific installation.

#### **Model CP-PB Call Point Push Button activated**

- 1-3/4-inch (44.5 mm) diameter spring return black thermoset plastic push button
- Protective faceplate wall shroud about the button and status indicator

#### **Model CP-BG Call Point Break Glass activated**

- Replaceable break glass panel covered with a protective polyester label to limit glass particle fallout
- Protective faceplate wall shroud about the status indicator
- EN 54-11 approved British Standard model available (**NOTE:** Reset Keyway must not be installed during operation)
- Optional side mounted break glass hammer bar

#### **Federal Signal Manual Call Point Stations are available with the following optional features factory installed:**

- High-impact-resistant clear polycarbonate cover flap with or without various instructional labels (e.g., LIFT COVER, BREAK GLASS TO ACTIVATE) on interior face of the cover flap
- Single and dual switches
- EN54-11 certified Break Glass stations

Federal Signal Manual Call Point Station may be field serviced with the Service/Accessory Kits specified within Table 5 page 19.

## Unpacking the Call Points Station

After unpacking the station, examine it for damage that may have occurred in transit. If it has been damaged, do not attempt to install or operate it. File a claim immediately with the carrier, stating the extent of the damage. Carefully check all envelopes, shipping labels, and tags before removing or discarding them. If any parts are missing, please call Federal Signal Customer Support at +1 708-534-4756 or +1 800-446-6809.

## Opening / Closing the Call Point for Internal Access

The Federal Signal Call Point stations have two chambers within their designs, the first being a front chamber housing the stainless steel mechanical hardware, and the rear chamber housing the activation switch and an internal wiring block with housing provisions for M8 or 1/4-inch mounting hardware through the four corner slotted openings.

**NOTE:** The design is such that the rear chamber may be accessed with no need to open the front chamber.

Tools needed to access both chambers:

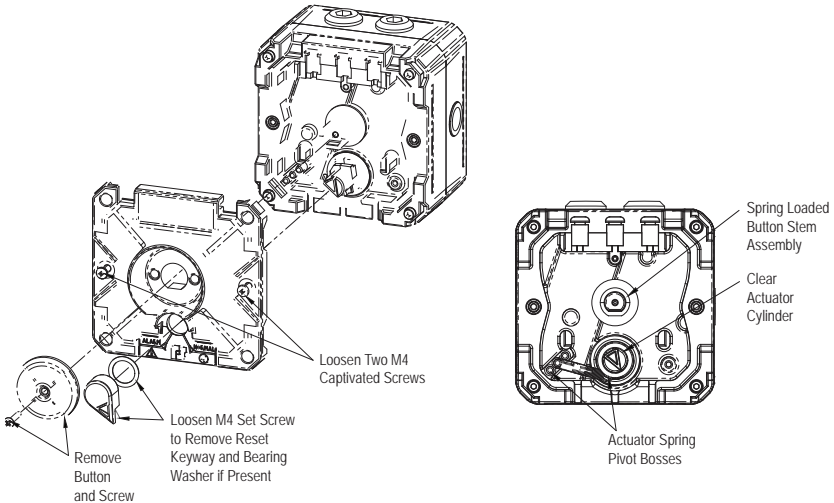
- #2 Philips screwdriver
- 2.0 mm hexagon key
- 3.0 mm hexagon key

## Call Point Front Chamber Access

The model CP-PB pushbutton station's front chamber is easily accessed for cover flap attachment and/or maintenance or replacement of parts. To access the front chamber:

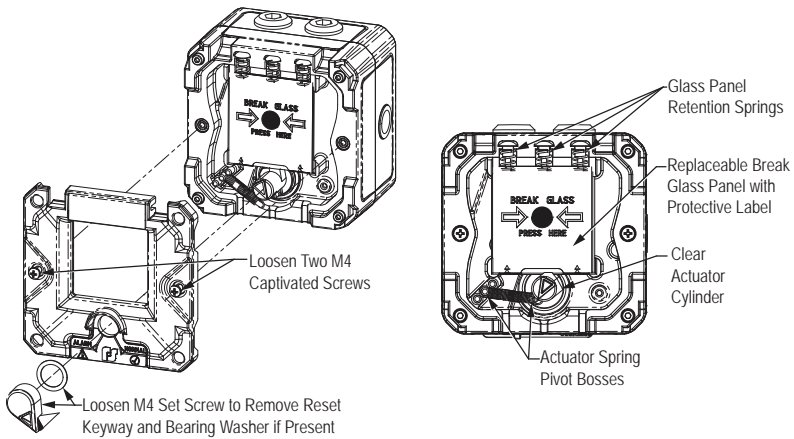
1. Remove the pushbutton and bearing washer by unscrewing the 3/4-inch long Philips screw.
2. If present, remove the reset keyway by using a M2 hex wrench to loosen the M4 set screw below the keyway's triangular pointer

**Figure 1 Removing the keyway**



3. Loosen the two M4 Philips head screws at the 3:00 and 9:00 positions on the faceplate and remove the faceplate.  
**NOTE:** These two screws are captivated to the front faceplate.
4. Upon reinstalling the front faceplate, reverse this process and apply 15 in-lb maximum of torque to the M4 Phillips screws to ensure that the faceplate is fully seated on the front housing.  
**NOTE:** Applying excessive torque may result in the brass threaded insert dislodging from the front housing, rendering the unit inoperable.

**Figure 2 Reinstalling the faceplate**



5. Model CP-BG break glass station's front chamber is easily accessed by the following actions:
  - a. If present, remove the reset keyway by using an M2 hex wrench to loosen the M4 set screw below the keyway's triangular pointer
  - b. Loosen the two M4 Philips screws at the 3:00 and 9:00 positions on the faceplate and remove the faceplate.  
**NOTE:** These two screws are captivated to the front faceplate
  - c. Upon reinstalling the front faceplate, apply 15 in-lb maximum of torque to the M4 Philips screws to ensure that the faceplate is fully seated on the front housing.  
**NOTE:** Applying excessive torque may result in the brass threaded insert dislodging from the front housing rendering the unit inoperable.

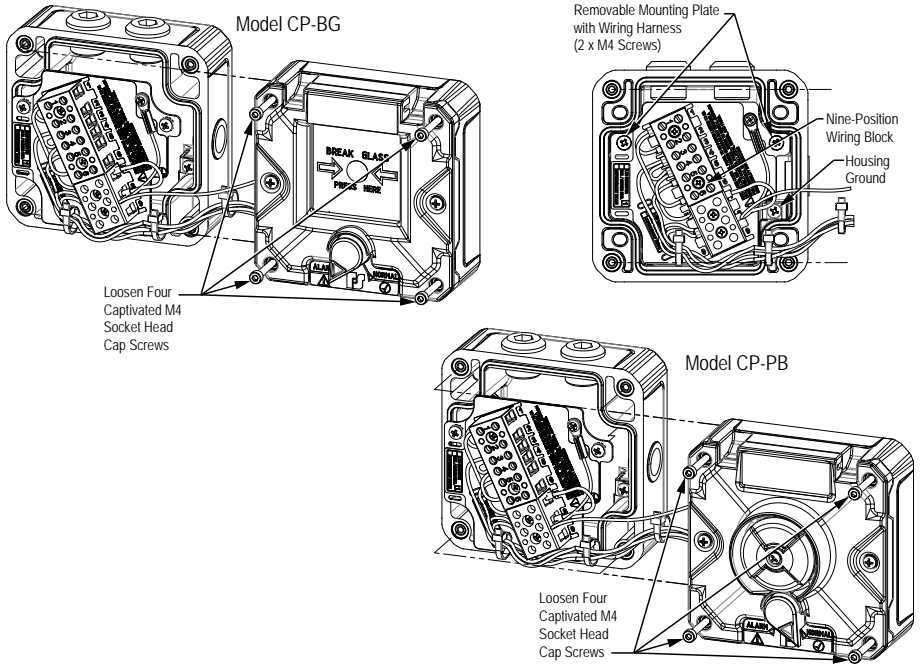
### Call Point Rear Chamber Access

All models of the Call Point station have the same rear chamber access method for internal wiring management, mounting the unit to a vertical wall surface, and general maintenance/routine inspection.

To access the rear chamber:

1. Loosen the four captivated socket head cap M4 screws by using a M3 hex wrench at each of the front corners of the device.
2. Carefully pull away the front housing portion from the rear, noting the limited extension length of the two halves due to the wiring harness length.
3. Note that the rear housing unit is 180° rotatable with respect to the front housing so the two threaded entryways can be on either the top or bottom of the installed station.
4. Upon reinstalling the front housing, screw down a pair of diagonally opposed screws first by partially applying 18 in-lb maximum of torque to the M4 socket head screws. Repeat the process to the other two diagonally opposed screws, and then return back to the first two, repeating the process in order to evenly tighten the station to ensure that the housing is fully seated on the gasket.  
**NOTE:** Applying excessive torque may result in the brass threaded insert dislodging from the rear housing, rendering the unit inoperable.

**Figure 3 Common Internal View**



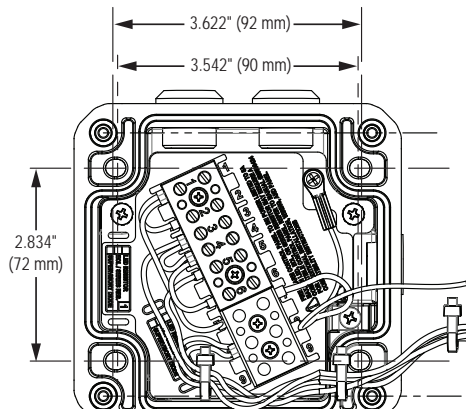
## Mounting the Call Point Station

### **⚠ WARNING**

**ATTACH THE STATION SECURELY:** To prevent injury, this apparatus must be securely attached to the mounting surface in accordance with the installation instructions and local jurisdictions and codes. Use installer-supplied fasteners suitable for the mounting surface.

All models of the Call Point station have the same rear chamber access to four corner oval-shaped holes for mounting the station to a rigid vertical wall surface. The devices may be mounted by using four M6 metric threaded fasteners or four 1/4-inch or #12 threaded fasteners that are installer-supplied. Be sure to follow all national and local jurisdictions and codes as to placement of the station within the appropriate environment.

**Figure 4 Mounting Layout**



**SAFETY MESSAGES TO INSTALLING AND WIRING** ⚠️: Products should be installed by a licensed electrician and follow all safety instructions. Failure to do so may result in property damage, serious injury, or death. When installing and operating the stations, the relevant national regulations for installation and operation (e.g., EN60079-14, IEC Wiring Regulations, and NEC/CEC) along with any additional national and local codes/requirements must be observed.

**⚠️ WARNING**

- To avoid electrical shock hazards, do not connect wires when power is applied. Failure to observe this warning may lead to serious injury or death.
- Painting and surface finishes, other than those applied by Federal Signal Corporation, are not permitted.
- Wiring terminations should be in accordance with specifications within this manual and required by national and local requirements, depending on the application. Federal Signal recommends that all wiring leads be fully identified.
- In all countries, the wiring must comply with all national and local codes and standards.
- Ensure that all hardware connections are secure. Stainless steel fasteners must be used in corrosive environment applications mounting the station to a rigid surface.
- Ensure that all cable glands and stopping plugs are certified with a suitable sealing washer/o-ring to ensure the NEMA/IP rating of the station.
- The internal earth ground terminal must be used for equipment grounding where and when required.

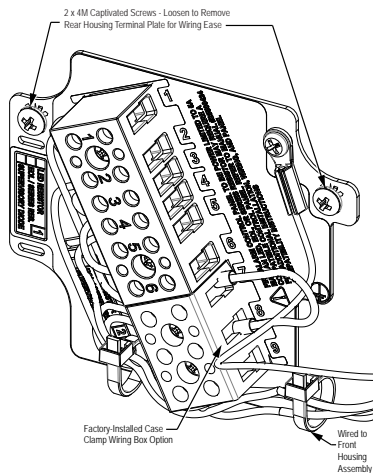
### Internal Rear Chamber Wiring

**⚠️ WARNING**

**SHOCK HAZARD: To avoid electrical shock hazards, do not connect wires when power is applied. Failure to observe this warning may lead to serious injury or death.**

All Federal Signal Call Points stations are supplied with a standard nine-position wiring block mounted to a removable aluminum bracket for ease of wiring if desired. Multiple factory pre-terminated wiring layouts are available, depending on the options that the station will have installed:

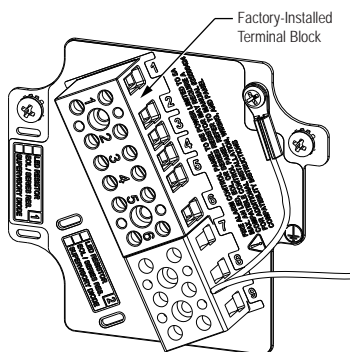
**Figure 5 Internal rear chamber wiring**



- Wire gauge range is 0.5 to 4.0 mm, (12-20 AWG) for either solid or stranded conductors.
- Strip length of 9 - 10 mm (0.35 - 0.39 inch)



**Figure 6 Block wiring option**



- Wire gauge range is 0.5 to 4.0 mm, (12-22 AWG) for either solid or stranded conductors.
- Strip length of 8 mm (0.315 inch)
- The cross-sectional area of the primary earth (ground located within the rear housing) must equal the cross-sectional area of the phase conductor.
- The incoming wire must be rated per the corresponding national and local codes in which the station is used.

Tools needed (after internal access):

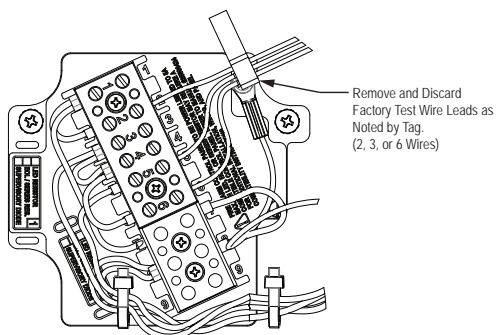
- Wire stripper
- 4.0 x 0.8 mm or 1/8" slotted screwdriver

To wire the CP-PB (pushbutton) and CP-BG (break glass) models:

1. If desired for easier access, loosen the two captivated M4 Philips screws on the aluminum mounting bracket and remove it from the rear housing, taking care, as it still remains directly wired to the front housing assembly.
2. Strip the incoming wiring leads to the station to the appropriate length as noted above (depending on wiring block configuration).

**NOTE:** Ensure that the incoming lead lengths into the station meet the required national and local regulations/codes and also that the leads are not excessive in length causing the station not to be reassembled.

**Figure 7 Factory test wires**



3. Remove the 22 AWG factory test leads (as noted by tag around them) from the terminal wiring block and discard them.
4. Reference the following wiring schematic diagrams for your station and its application within your system. Wire per the diagram shown.
5. Ensure that all wires are properly seated and restrained to the station's wiring or terminal block.

- Route/tuck in the wiring into the rear housing of the unit and carefully reassemble the unit's front and rear housings so that both fully seat to each other when the four M4 screws are tightened. Alternate between tightening the diagonal pairs of screws to ensure that the station's housings are tightened evenly.

### Standard SPDT and DPDT Devices Switch Wiring

For the standard-issue SPDT and optional DPDT models, please note the following applicable requirements for these specific models:

- A factory-installed jumper is supplied across input terminals 7 and 8 of the single pull double throw switch device; on a double pull double throw device, input terminals 6, 7, and 8 are used as secondary inputs with common.

Figure 8 Standard SPDT switch wiring

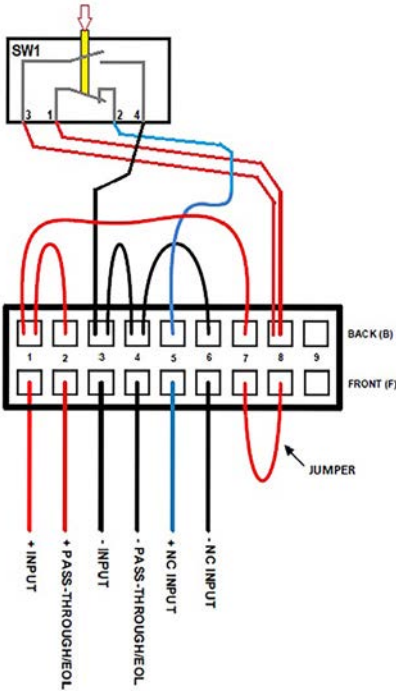
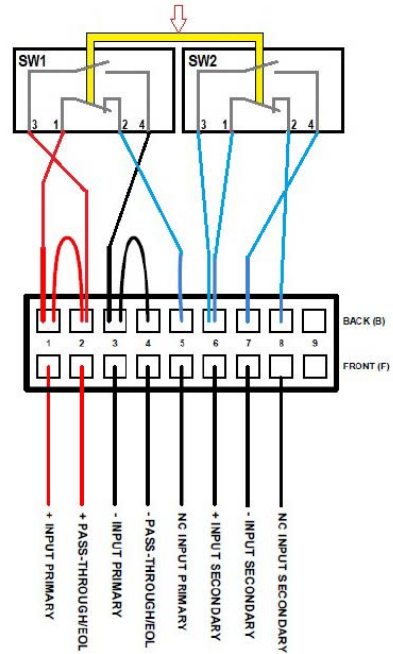


Figure 9 Standard DPDT switch wiring



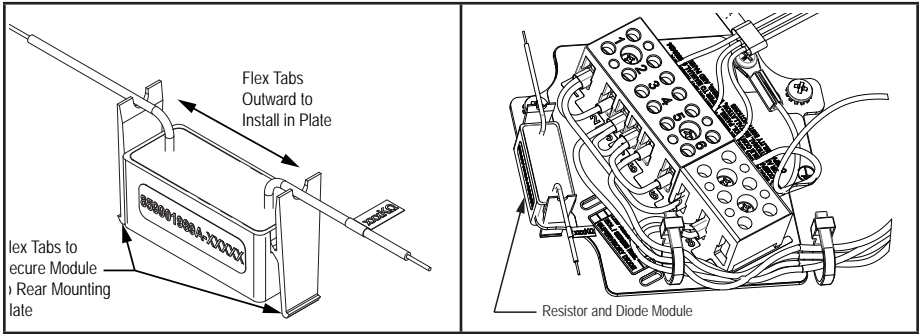
Optional EOL, Diode, and Series Resistor Module Install and Wiring, SPDT and DPDT devices:

#### **⚠ WARNING**

For the SPDT and DPDT models with optional field installed EOL or Series Resistor Module(s), please note the following applicable requirements for these specific models:

- When using with a fire alarm control panel, the panel is to be limited to 5 A maximum. An LED, EOL, or series resistor may require a compatible control panel.
- The separately supplied EOL and Series Resistor (as well as Diode) modules are installed via snap-fit clips into two possible locations on the rear mounting plate for wiring ease and replaceability:

Figure 10 Snap fit clips



## Fire Alarm Control Panel (FACP)

For Federal Signal Call Points stations (Model CP-PB and CP-BG), a compatibility check must be made of the station(s) when installed to a FACP.

### **⚠ WARNING**

Failure to conduct a compatibility check per the guidelines listed below may lead to property damage, serious injury, or death.

- Standby Mode Impedance: Equal to the EOL Resistor value (no EOL Resistor equals infinite  $\Omega$ ).
- Alarm Mode Impedance: Equal to the Series Resistor value (no Series Resistor equals  $0\Omega$ ).

## Electrical Specifications

Maximum Input Voltage: 48 Vdc maximum.

Maximum Input Current: 5 A / 1 A\*

\*1 A with FS-approved diode installed (See Table 5 on page 19 for the diode part number.)

### **⚠ WARNING**

Before connecting to the power, confirm that the external voltage source and internal EOL/Series resistor values are in accordance as shown above. The resistance of the resistor modules are marked on the resistor module enclosures. If the EOL/series resistor value chosen is outside the range above, the hazardous area safety protection of the Ex potted module is compromised. The maximum power dissipation on the resistor is 1 W. Failure to observe this warning may lead to property damage, serious injury, or death.

Maximum Ground Wire: 12 AWG / 2.05 mm

## Manual Test and Reset Operation of the Station

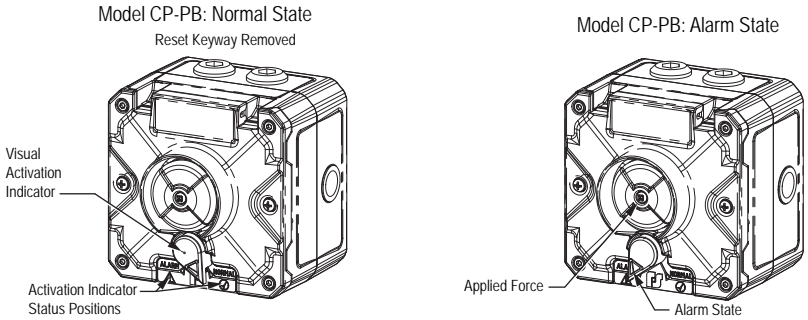
The CP-PB and the CP-BG stations have separate activation techniques for placing the internal switch into the alarm state and resetting the stations to normal after the alarm state. Follow the instructions according to your station type.

### CP-PB Stations

Activation Test

For the manual pushbutton stations, activation is accomplished by a front force directly inward towards the station against the black pushbutton, locking the pushbutton in an alarm state. Upon doing so, the activation indicator with a reset keyway on the front face located directly below the pushbutton will rotate approximately 60° clockwise, positioning itself in the direction of the ALARM state away from the NORMAL standby state. Ensure that the proper switch activation has occurred and that the associated control panel is in alarm mode for the station.

**Figure 11 CP-PB States**



**Reset Test**

For the manual pushbutton stations, resetting is accomplished by rotating the activation indicator approximately 60° counterclockwise by use of a reset keyway that is mated to the activation indicator. Upon rotating counterclockwise, the pushbutton knob, along with the internal switch, will be released from the activated ALARM states and return to the NORMAL standby positions as noted on the station's front faceplate. Ensure that the proper switch deactivation has occurred and that the associated control panel returns to normal standby mode for the station.

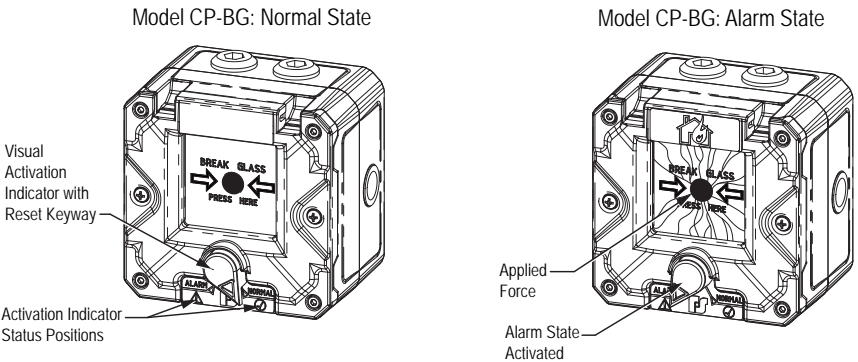
**CP-BG Stations**

**Activation Test**

For the manual break glass stations, activation may be accomplished by either of two means:

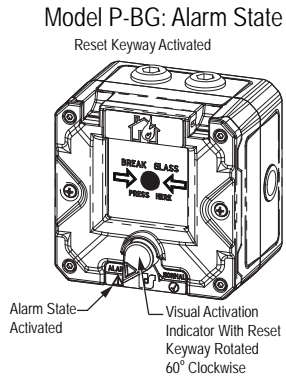
1. Applying a front force directly inwards towards the station against the glass panel, which is noted with BREAK GLASS PRESS HERE along with a corresponding target dot to apply the force to break the glass panel. A polyester label is attached on the glass panel to protect the user from glass particles when the panel is broken. Once broken, the unit must have the panel replaced for resetting it.

**Figure 12 CP-BG States**



- Using the reset keyway (factory attached on non- CP-BG-x-x-x-xxx-xx-2 stations) mated to the faceplate's activation indicator, rotate the indicator approximately 60° clockwise until the indicator notes ALARM. The glass panel will physically be displaced upward during this action, and the internal switch will be activated without breaking the glass panel. This provides a means of testing the station without breaking the glass panel.  
**NOTE:** On CP-BG-x-x-x-xxx-xx-2 (EN54-11) models the keyway is not factory attached; it is supplied separately within the packaging. Per EN54-11 standards and regulations, it is to be used separately as a discrete standalone keyway to reset an EN54-11 Call Point station.

**Figure 13 CP-BG alarm state**



Upon doing either, the activation indicator with or without the reset keyway will be rotated approximately 60° clockwise in the direction of the ALARM state away from the NORMAL standby state, triggering the internal switch. Ensure that the proper switch activation has occurred and that the associated control panel is in alarm mode for the station.

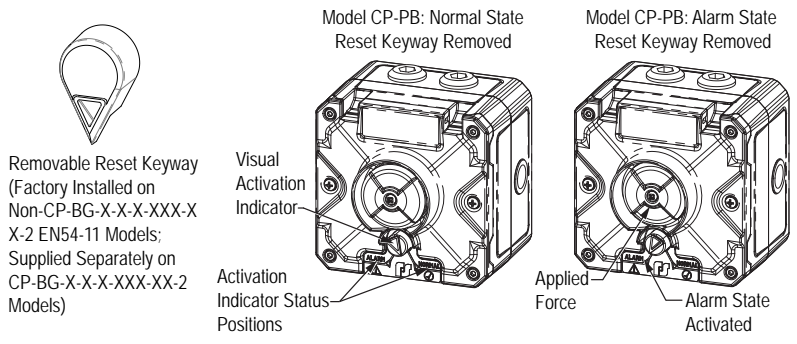
*Reset Test*

For the manual break glass stations, resetting is accomplished by either of two methods (following the previously mentioned two methods of activating the stations):

- To replace the broken glass panel, follow the directions on page 14. Once replaced, the internal mechanism should be back to its NORMAL standby position as noted on the station's front faceplate. Ensure that the proper switch deactivation has occurred and that the associated control panel returns back to normal standby mode for the station.
- To reset the glass panel in the NORMAL state (the glass panel is unbroken), rotate the activation indicator approximately 60° counterclockwise by use of a reset keyway that is mated to the activation indicator. Upon rotating counterclockwise, the glass panel will move slightly downward, and the internal switch will be released from its activated ALARM state, returning the station back to its NORMAL standby position as noted on the station's front faceplate. Ensure that the proper switch deactivation has occurred and that the associated control panel returns back to normal standby mode for the station.

**NOTE:** if the reset keyway (which is NOT factory installed on EN54-11 stations) remains installed on the activation indicator, the action remains the same, with a larger indicator showing the station's status. BUT the possibility of access to resetting the station is evident to those reasonably knowledgeable of its operation that are nearby, which may result in false signals being sent to the indicating control panel. Refer to page 16 for instructions on removing the factory-installed keyway for use only by authorized personnel. Failure to observe this warning may lead to property damage, serious injury, or death.

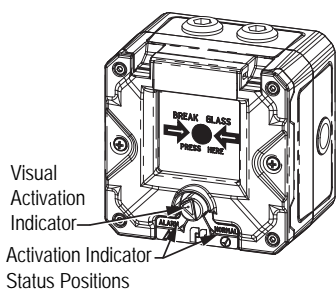
**Figure 14 CP-PB states without reset keyway**



**Figure 15 CP-BG states without reset keyway**

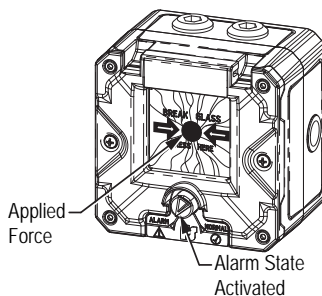
**Models CP-BG: Normal State**

Reset Keyway Removed




**Models CP-BG: Alarm State**

Reset Keyway Removed



### Safety Messages to Maintenance Personnel

**SAFETY MESSAGES TO INSTALLERS AND USERS** : Products should be installed by a licensed electrician and follow all safety instructions. Failure to do so may result in property damage, serious injury, or death. Listed below are some important safety instructions and precautions you should follow with regards to all instructions within this manual:

- Read and understand all instructions before operating this system.
- If you acquired a significant quantity of units, then it is recommended that spares be made available.
- Any maintenance to the Call Points station must be done with the power turned off.
- Any maintenance to the Call Points station must be performed by a trained electrician who is thoroughly familiar with all applicable national and local codes in the country of use.
- Never alter the unit in any manner. The unit's safety may be affected if additional openings or other alterations are made to the internal components or housing.
- The nameplate, which may contain cautionary or other information of importance to maintenance personnel, should NOT be obscured in any way. Ensure that the nameplate remains readable.
- After performing any maintenance, test the Call Points station to ensure that it is operating properly.

Failure to follow all safety precautions and instructions may result in property damage, serious injury, or death.

### Maintaining/Modifying the Call Point Station

During the working life of the station, it should require little or no maintenance. The non-metallic front and rear glass reinforced polyester (GRP) housings will resist attack by most acids, alkalis, and chemicals and is as resistant to concentrated acids and alkalis. The front faceplates are of the same material with an acrylic color overcoat. However, if abnormal or unusual environment conditions occur due to plant damage or accident, etc., visual inspection of the Call Point station is recommended. Replacement front faceplates are available if a need arises.

### Cleaning the Enclosure

The housing/faceplate enclosure should be cleaned periodically with a damp cloth to maintain the legibility of all labels and icons. While cleaning, if it is noticed that any part of the station is damaged, it must be replaced to maintain the functional integrity of the device. Reference the service/accessory parts section of this manual to do so.

### Replacing the Break Glass Panel (CP-BG units)

To replace a broken glass panel on the station:

 **WARNING**

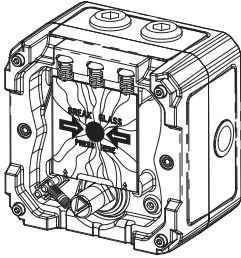
**CUTTING HAZARD:** Safety gloves are required when accessing the internal front chamber with a broken glass panel in order to prevent wounds.

1. Carefully remove the front faceplate to access the front chamber. Caution should be taken, as sharp glass pieces may be evident, which may result in wounds.
2. Remove and carefully discard the remaining panel pieces from the front chamber and any that may have fallen outside the chamber/station.

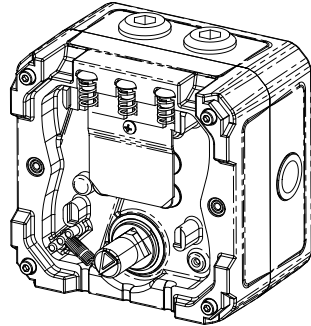
**Figure 16 Broken glass**

Model CP-BG: Alarm State

Front Chamber Access – Break Glass Removal

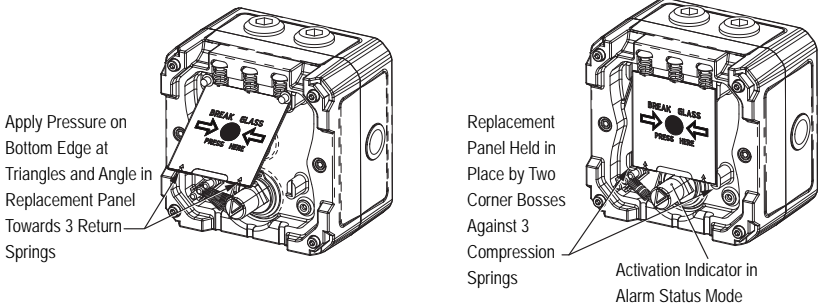


**Figure 17 Glass panel removed**



3. Position the replacement glass panel at an angle as shown in the following illustration with its top edge placed against the three return bias springs. Along the bottom edge, place your thumb at the dual black triangles on either side. Applying pressure to the panel with the both thumbs, push upward toward the three springs—enough to wedge the glass panel next to the activation indicator's cam surface and into the two corner bosses holding the panel in place. The panel should now be constrained so that it does not push itself outward.

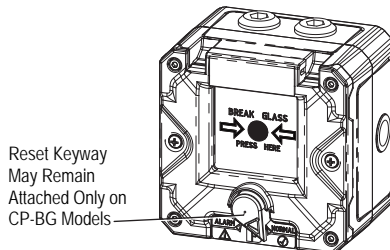
**Figure 18 Replacing the glass**



4. Reattach the front faceplate.
5. Note that the activation indicator is in ALARM status mode. With the reset keyway attached, rotate the indicator about 60° counter-clockwise if it is desired to return to NORMAL status mode.

**Figure 19 Returning to a normal state**

Model CP-BG: Normal State

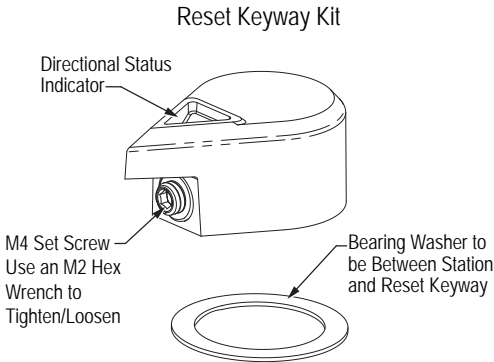


## Installing/Serviceing the Reset Keyway

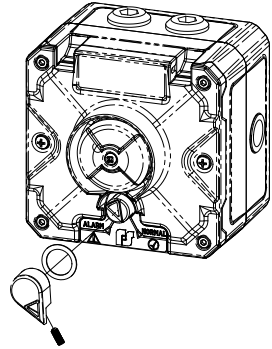
The reset keyway is factory-attached on the CP-PB and CP-BG stations. On the CP-BG-x-x-x-xxx-xx-2 (E54-11 approved) stations, it is provided separately to be used only as a discrete standalone key. On these models, the key should not be permanently installed for EN-54-11 installations and shall be used only for test purposes. Its purpose is twofold:

1. Provide a means of resetting all devices after an activated ALARM status by a 60° counter-clockwise rotation of the activation indicator.
2. Provide a means of ALARM activation testing of the CP-BG stations without breaking the glass panel.

**Figure 20 Reset keyway kit**



**Figure 21 Keyway location**



Removal/attachment of the reset keyway is easily done by use of a M2 hex wrench mated to the M4 set screw below the triangular directional status indicator. The set screw need not be fully removed from the keyway, only loosened enough to lift the keyway along with the bearing washer from the unit's status indicator.

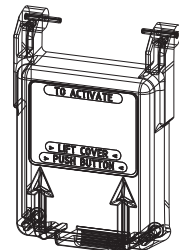
## Installing/Serviceing the Optional Cover Flap

An optional, clear, polycarbonate cover flap is provided either factory-attached on the CP-PB and CP-BG stations or as a field-installable kit. The cover flap may also be ordered with a clear instructional label attached (e.g., IN CASE OF FIRE LIFT COVER BREAK GLASS, IN CASE OF FIRE LIFT COVER PUSH BUTTON, TO ACTIVATE LIFT COVER BREAK GLASS, and TO ACTIVATE LIFT COVER PUSH BUTTON). The IN CASE OF FIRE LIFT COVER BREAK GLASS marking must be present on EN54-11 certified models.

To remove or remove/reattach a cover flap:

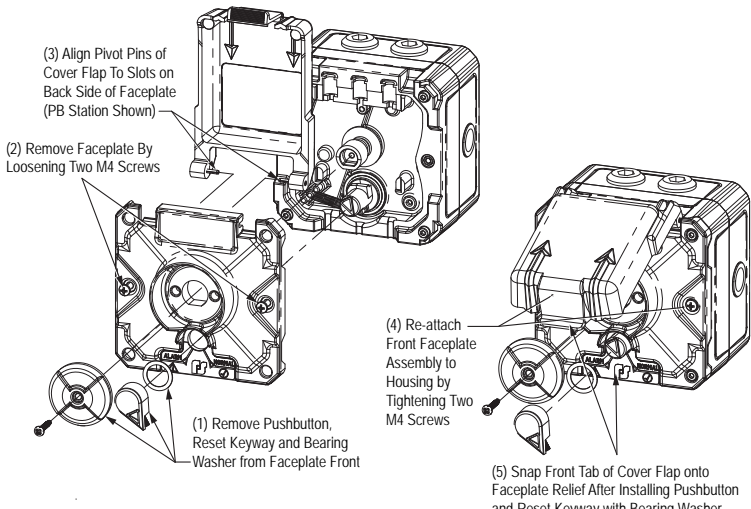
1. Remove the front faceplate per directions found earlier in "Call Point Front Chamber Access" on page 5. Place the two stainless steel pivot pins of the cover flap within the slot found on the backside of the faceplate, and rotate the cover 180° to snap the cover flap onto the front face.
2. Reattach the faceplate (See "Opening / Closing the Call Point for Internal Access" on page 5), and then open the cover to reattach the pushbutton and the reset keyway if they are provided with the station.
3. Ensure that access to the activation pushbutton or glass panel is easily accomplished by lifting the cover flap upward.

**Figure 22 Cover**





**Figure 23 Assembly**



### Installing/Serviceing the Optional Break Glass Hammer Bar

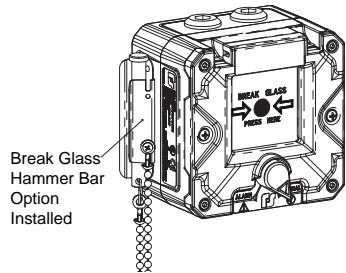
**NOTE:** The break hammer bar kit cannot be used with stations that already have a side stainless steel duty label already attached to the station.

The optional break glass hammer bar kit is side-mounted on the rear housing of the station as a factory or field installed option. The kit contains all the parts necessary if replacement parts are required for existing damaged or missing parts of the break glass hammer bar option.

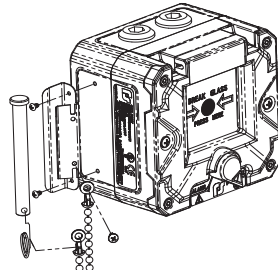
### Assembly with two mounting screws

The hammer bar can be pulled directly out from its retaining bracket for access to the two mounting holes that are for the attachment of the two supplied #4 screws. Carefully screw the bracket onto the rear housing. **DO NOT OVERTIGHTEN AS THIS MAY DAMAGE THE THREAD ENGAGEMENT TO THE REAR HOUSING.**

**Figure 24 Hammer installed**



**Figure 25 Attaching the bracket**



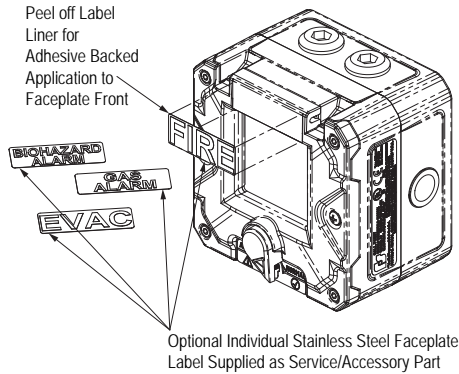
### Installing/Serviceing the Optional Stainless Steel Faceplate Labels

**NOTE:** The stainless steel faceplate labels are only to be used on non-EN54-11 stations. Applying one of these labels over the factory-installed EN54-11 flaming building label will void its certification.

These labels are provided separately as a service/accessory part. (See the Replacement Parts table on page 19.) Available black text on the labels are FIRE, EVAC, GAS ALARM, or BIOHAZARD ALARM. The labels have a peel-off paper

liner exposing a pressure-sensitive adhesive backing. Initial placement is critical, as the adhesive is aggressive, once it touches the station faceplate's designated label area. Make sure the application area is free from any dirt, smudges, or oil prior to application.

**Figure 26 Installing the label**

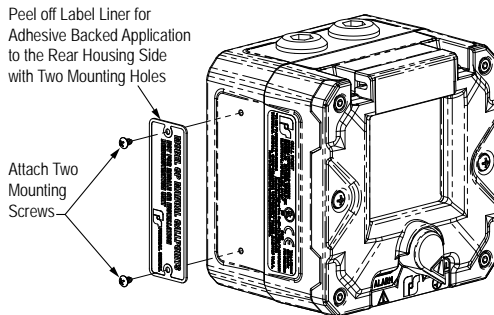


### Installing/Serviceing the Optional Stainless Steel Custom Duty Plate

**NOTE:** The stainless steel Duty Plate kit cannot be used with BG (break glass) stations that have the Hammer Bar option already installed.

These plates are provided separately as a custom order service/accessory part (see Table 5 on page 19), having the end user provide desired text/artwork for their specific application. The duty plates have a peel-off paper liner exposing a pressure-sensitive adhesive backing. Initial placement is critical as the adhesive is aggressive once it touches the station faceplate's designated label area. Make sure the application area is free from any dirt, smudges, or oil prior to application. Two screws are also provided so that the plate is securely held in place during the station's life usage. Consult the factory for the lead time regarding the fabrication of custom duty plates along with minimum order quantity.

**Figure 27 Installing the custom duty plate**



### Lubricating the Threaded Joints

A silicone-based, non-hardening, chemically compatible grease may be applied if required only on the rear housing's three threaded inlet ports.

**NOTE:** When using a silicone-based grease, use caution in not applying it to the housing gasket or other parts located on the front housing assembly. Failure to do so may compromise the sealing integrity of the device.

## Maintenance and Service

### **⚠ WARNING**

**EXPLOSION HAZARD:** Do not disconnect the equipment while the circuit is live or unless the area is known to be free of ignitable concentrations.

### **⚠ WARNING**

**EXPLOSION HAZARD:** To prevent the ignition of hazardous atmospheres, disconnect the fixture from the supply circuit before opening.

### **⚠ WARNING**

**EXPLOSION HAZARD:** Substitution of any component may impair suitability for Class I, Division 2.

## Service

**Technical Assistance:** Contact our Technical Support Team at +1 708-587-3587 or [signalsupport@fedsig.com](mailto:signalsupport@fedsig.com).

**Repair Service:** A return authorization is required. Contact your Authorized Distributor or Federal Signal Customer Support. Defective products under warranty will be repaired or replaced at Federal Signal's discretion.

**Product Returns:** Returns require authorization from Federal Signal. Contact your Authorized Distributor for more information on our return policy or to request a return.

## Replacement Parts

Contact the factory for spare parts availability and part numbers. Typical spare parts are listed below. Due to certification, certain component parts are not available for field replacement. Units with this type of damage must be either replaced entirely or returned to Federal Signal for service.

**Table 4 Call Points Field Installed Service/Accessory Kits**

Part Description	Federal Signal Part #	Use
Break Glass Panel, 5-Pack	K859902275A	CP-BG stations
Cover Flap	K859901982A	CP-BG and CP-PB stations
" " w/Label (IN CASE OF FIRE / BREAK GLASS)	K859901982A-01	CP-BG stations
" " w/Label (TO ACTIVATE / BREAK GLASS)	" -02	" " "
" " w/Label (IN CASE OF FIRE /PUSH BUTTON)	" -03	CP-PB stations
" " w/Label (TO ACTIVATE /PUSH BUTTON)	" -04	" " "
Break Glass Hammer Bar w/chain	K859902546A	CP-BG stations
Potted Resistor Module, 470Ω	K859901989A-0470	EOL/Series Resistor
" " " 1KΩ	" -1000	" " "
" " " 1.8KΩ	" -1800	" " "
" " " 2.2KΩ	" -2200	" " "
" " " 2.4KΩ	" -2400	" " "
" " " 3.3KΩ	" -3300	" " "
" " " 3.6KΩ	" -3600	" " "
" " " 4.7KΩ	" -4700	" " "
" " " 5.6KΩ	" -5600	" " "
" " " 10KΩ	" -10000	" " "
" " " 12KΩ	" -12000	" " "

Part Description	Federal Signal Part #	Use
" " " 15KΩ	" -15000	" " "
" " " 22KΩ	" -22000	" " "
" " " 33KΩ	" -33000	" " "
" " " 47KΩ	" -47000	" " "
Potted Diode Module, 5A	K859901990A	5A Supervisory Diode Module
Reset Keyways, 5-Pack	K859902467A	CP-BG and CP-PB stations
Break Glass Faceplate, Red	K859902471A-BGRD	CP-BG stations
" " " Yellow	" -BGYL	" " " (Non EN54-11)
" " " Blue	" -BGBL	" " " (Non EN54-11)
" " " Green	" -BGGR	" " " (Non EN54-11)
" " " Black	" -BGBK	" " " (Non EN54-11)
Push Button Faceplate, Red	K859902471A-PBRD	CP-PB stations
" " " Yellow	" -PBYL	" " "
" " " Blue	" -PBBL	" " "
" " " Green	" -PBGR	" " "
" " " Black	" -PBBK	" " "
Faceplate Labels (6) Sheet, White (FIRE,EVAC,.....)	K71400935A-01	CP-BG and CP-PB red, blue, green and black stations, (Non EN54-11)
" " " " Black (FIRE,EVAC,.....)	" -02	" " " yellow stations
Faceplate Label EN54-11	K71400701A	CP-BG-x-x-x-xxx-xx-2 EN54-11 stations
Faceplate Label, Stainless Steel, FIRE	K71400976A-01	CP-BG and CP-PB stations, (Non EN54-11)
" " " " EVAC	" -02	" " " " (Non EN54-11)
" " " " BIOHAZARD ALARM	" -03	" " " " (Non EN54-11)
" " " " GAS ALARM	" -04	" " " " (Non EN54-11)
Actuation Label, White	K71400699A-01	CP-BG and CP-PB red, blue, green and black stations
" " " Black	" -02	" " " yellow stations
Duty Label Stainless Steel with Custom Artwork/Text	K859902480A	Cannot be mounted with hammer bar option. Consult factory for lead time.



**FEDERAL SIGNAL**  
Safety and Security Systems

2645 Federal Signal Drive, University Park, Illinois 60484

Additional translations available at [signaling.fedsig.com](http://signaling.fedsig.com)

Traducciones adicionales disponibles en [signaling.fedsig.com](http://signaling.fedsig.com)

Customer Support 1-800-344-4634+1-708-534-4756, [iordersup@fedsig.com](mailto:iordersup@fedsig.com)

Technical Support 1-800-755-7621+1-708-587-3587, [signalsupport@fedsig.com](mailto:signalsupport@fedsig.com)

[signaling.fedsig.com](http://signaling.fedsig.com)

