



# FALCO 2 and FALCO 2 <sup>TAC</sup>

Instrument User Manual V1.2

---



Register  
your instrument  
online to receive your  
extended warranty.

## **Register your instrument online for extended warranty**

Thank you for purchasing your Ion Science instrument.

The standard warranty of your FALCO 2 VOC Monitor is for one year.

To receive your extended warranty, you must register your instrument online within one month of purchase (terms and conditions apply).

Click [here](#) to extend your instrument warranty, or scan the QR code below.





**Contents**

**Safety .....6**  
    Legal Notices Regarding the Safe Operation of Equipment ..... 6  
    Symbols ..... 6  
    Warnings, Cautions and Information notifications ..... 6  
    Disposal ..... 8

**Certification .....8**

**Statements .....8**  
    Responsibility for Correct Use ..... 8  
    Warnings ..... 8

**Introduction to FALCO 2.....9**

**Specification .....10**

**Unpacking and inspection .....12**  
    Diffused Unboxing:..... 12  
    Pumped unboxing: ..... 12

**System Description .....13**  
    Outputs and Communications ..... 13

**RS 485 Modbus Interface .....13**  
    Modbus Error Status Bit Mask Explanation:..... 14  
    Error Register Bit Assignments ..... 14  
    Interpreting the Error Register Value ..... 15  
    Usage Notes ..... 15

**Installation Requirements .....15**  
    Location Requirements ..... 15  
    Power Requirements ..... 16  
    Cable and Gland Requirements ..... 16

**Installation .....16**  
    Preparation for Installation ..... 16  
    Dimensions for Installation ..... 17  
    To Install the Housing Module ..... 18  
    After-Installation Test ..... 19  
    Installation in Zones with Explosive Atmospheres ..... 19

**Configurations of the 4–20 mA Current Loop .....19**



**Calibrating the 4 – 20 mA ..... 21**  
    4–20 mA setup ..... 21  
    4–20 mA Fault scaling ..... 22

**Hydrophobic Filter ..... 23**  
    Sampling Tube Length ..... 23

**Removal of the Control Module ..... 23**  
**To Remove the Control Module ..... 23**

**Operating the FALCO ..... 24**  
    User Interface..... 24  
    Status Light..... 24

**Start-Up Routine ..... 25**  
    Logo Screen ..... 25  
    Info screen 1..... 25  
    Info screen 2..... 25  
    Warm-up ..... 25

**Normal Running Mode Screen ..... 26**  
    Software Screens..... 26  
    Software Flow Chart..... 26  
    Lock Screen ..... 27  
    Navigating the Menus and Selecting Menu Options..... 27  
    Menu i1 ..... 28  
    Menu i2 ..... 28  
    Menu i3 ..... 28  
    Menu i4 ..... 29  
    Menu i5 ..... 29  
    Menu i6 ..... 29  
    Menu i7 ..... 30  
    Menu i8 ..... 30  
    Pump Operation..... 30

**Calibration ..... 31**  
    Zero ..... 31  
    Span 1..... 32  
    Span 2..... 33

**RF (Response Factor) ..... 33**



**Detection Units** ..... **34**

**Measurement Cycle** ..... **34**

**Alarms** ..... **35**

    Alarm 1 ..... 35

    Alarm 2 ..... 35

**Alarm Brightness** ..... **35**

**Alarm Pulsing** ..... **36**

**Relays** ..... **36**

*Relay 1 Options* ..... 36

*Relay 2 Options* ..... 37

**4-20 mA** ..... **37**

*4–20 mA Enable/Disable* ..... 37

*4 - 20mA Range* ..... 37

**Modbus Address** ..... **37**

**Status Light Brightness** ..... **38**

**Service Mode** ..... **38**

**Password Lock** ..... **39**

**Servicing** ..... **39**

    Filter Disc Replacement ..... 40

    Bump Test ..... 40

**Cleaning the MiniPID** ..... **41**

    Reassembly ..... 42

    Use of PID Lamp Cleaning Kit A-31063 ..... 42

    Hazard identification ..... 42

    Handling ..... 42

    Storage ..... 42

**Fault Diagnostics** ..... **43**

    Alarm and Fault Indications ..... 43

    Fault Conditions ..... 43

**Manual Log** ..... **44**

**Quality Assurance** ..... **45**

**Warranty** ..... **45**

**ION Science Contact Details** ..... **46**

## Safety

### Legal Notices Regarding the Safe Operation of Equipment

- Whilst every attempt is made to ensure the accuracy of the information contained in this manual, ION Science accepts no liability for errors or omissions in the manual, or any consequences deriving from the use of information contained herein. It is provided “as is” and without any representation, term, condition or warranty of any kind, either expressed or implied.
- To the extent permitted by law, ION Science shall not be liable to any person or entity for any loss or damage which may arise from the use of this manual.
- We reserve the right at any time and without any notice to remove, amend or vary any of the content which appears in this manual.

### Symbols



**WARNING!**  
USED TO INDICATE DANGER WARNINGS WHERE THERE IS A RISK OF INJURY OR DEATH.



**Caution**  
Used to indicate a caution where there is a risk of damage to equipment.



**Information**  
Important information or useful hints about usage.



**Recycling**  
Recycle all packaging.



**WEEE Regulations**  
Ensure that waste electrical equipment is disposed of correctly.

### Warnings, Cautions and Information notifications

The following Cautions apply to the product described in this manual.



Inadequate performance of the gas detection equipment described in this manual may not necessarily be self-evident and consequently equipment must be regularly inspected and maintained.



ION Science recommends that personnel responsible for equipment use institute a regime of regular checks to ensure it performs within calibration limits, and that a record be maintained which logs calibration check data.



The equipment should be used in accordance with the safety standards and installation instructions given in this manual, and in compliance with local safety standards.



Protect the PID sensor from exposure to silicone vapors, as this may foul the windows of the lamps and reduce response to some gases. This can usually be remedied by polishing the lamp window with alumina powder.



Do not use abrasive or chemical detergents to clean the Falco instrument, as this may reduce the antistatic properties of the materials used; clean it using a damp cloth only.



The Falco must not be exposed to atmospheres known to have an adverse effect on Thermoplastic Elastomers or Polycarbonate.



Outside the items covered in this manual, the Falco must be serviced in a Non-Hazardous environment and by ION Science Ltd authorized service centers only. Substitution of components may impair intrinsic safety.



Ingress Protection: Continuous exposure to wet weather conditions should be limited to less than one day and harsh water spray conditions should be avoided.



Proper Use: If the equipment is used in a manner not specified by the manufacturer, the protection provided by the equipment may be impaired.

The following Warnings, Cautions and Information notifications appear later in this manual where they are applicable.



IF AN ALARM STATE IS TRIGGERED, THE USER SHOULD LEAVE THE HAZARDOUS ENVIRONMENT AND ACT IN ACCORDANCE WITH NATIONAL SAFETY REGULATIONS.



THE CLEANING COMPOUND CONTAINS ALUMINIUM OXIDE AS A VERY FINE POWER. THIS MAY CAUSE IRRITATION OF RESPIRATORY TRACT AND EYES. (CAS Number 1344-28-1).



Internal components must be handled with clean hands and clean tools. The lamp is fragile. Handle with great care. Never touch the window and do not drop.



Never refit a damaged Lamp.



The instrument **MUST** be re-calibrated after fitting a replacement or cleaned Lamp.



The Falco has been designed to be used in hazardous environments



**Important note:** Always check the calibration in normal running before use by carrying out a bump test. Apply the same Zero and SPAN gas used to calibrate and ensure the correct readings are displayed.

## Disposal

- The equipment does not include any toxic materials, but if it has been contaminated by toxic materials, then exercise due care and follow the appropriate regulations when disposing.
- Always adhere to local regulations and procedures when disposing of the equipment.
- Ion Science Ltd offers a take back service. Please contact us for more information.



### RECYCLING

Recycle all Packing.

### WEEE REGULATIONS

Ensure that all waste electrical equipment is disposed of correctly.

## Certification

- IECEx Certificate – IECEx FTZU 16.0011X
- ATEX Certificate – FTZU 15 ATEX 0113X
- North America Certificate – QPS LR1355

## Statements

### Responsibility for Correct Use

Ion Science Ltd accepts no responsibility for incorrect adjustments that cause harm or damage to persons or property. The users are responsible to respond appropriately to the readings and alarms given by FALCO.

Use the equipment in accordance with this manual, and in compliance with local safety standards.

Reduced performance of gas detection might not be obvious, so equipment must be inspected and maintained regularly. Ion Science recommends that you use a schedule of regular checks to ensure it performs within calibration limits, and that you keep a record of calibration check data.

### Warnings

1. Read and understand this Manual fully before you install or operate the FALCO.
2. For safety, the FALCO must only be operated by qualified personnel.
3. All electrical work must be only carried out by competent persons.
4. Substitution of components can result in unsafe conditions and will invalidate the warranty.
5. Surface mount fuses must only be replaced by Ion Science service centers.

## Introduction to FALCO 2

The FALCO 2 unit is a fixed detector for the continual monitoring and measuring of volatile organic compounds (VOCs) in the atmosphere. VOCs can be dangerous as they are poisonous to humans and there is a risk of explosion. VOCs are detectable using photo ionization detection (PID) detector.

The FALCO's multi colored LED status display screen can be seen up to 20 metres away in direct sunlight ensuring that personnel are alerted to hazards present.

The FALCO 2 has five magnetic switches with LED confirmation, a high contrast OLED screen, and graphical interface ensuring quick and easy installation and servicing.

The magnetic switches are operated with a magnetic pencil that provides the actions of up, down, left, right and enter.

The main display uses organic light emitting diode (OLED) technology and the status bar uses light emitting diodes (LED). It also has a galvanically separated 4-20 mA current loop, Modbus (serial communication protocol) and two configurable switched contacts.

For protection in explosive areas the FALCO's Main Unit electronics are fitted in an ExD enclosure and the PID Sensor Head utilizes intrinsically safe electronics.

The FALCO 2 has two modules:

- The **Main Unit** (flameproof enclosure)
- The **PID Sensor Head** (intrinsically safe)

The externally located, intrinsically safe PID sensor head allows servicing and calibration in a hazardous environment without having to isolate the power supply.

## Specification

Specification	Detail				
<b>Variant</b>	Falco 2.1 (Diffused) Falco 2.2 (Pumped) Falco <sup>TAC</sup>				
<b>Detector Principle</b>	Photo-Ionization Detector				
<b>Detection Range</b>	<b>Falco 2.1 (Diffused) / Falco 2.2 (Pumped):</b> 0 to 10 ppm, 0 to 50 ppm, 0 to 1,000 ppm, 0 to 3,000 ppm <b>Falco<sup>TAC</sup> (Diffused/Pumped):</b> 0 to 50 ppm				
<b>Detection Range</b>	0-10	0-50	0-50 (TAC)	0-1000	0-3000
<b>Stack</b>	White	Orange	White + Gold Spot	White	Orange
<b>Lamp</b>	10.6 eV	10.6 eV	10.0 eV	10.6 eV	10.6 eV
<b>Calibration Points</b>	2	2	2	3	3
<b>Resolution (ppm)</b>	0.001	0.01	0.01	0.1	1
<b>Accuracy</b>	± 5% ± 1 digit				
<b>Falco 2 Diffused T<sub>90</sub></b> <b>Falco 2 Pumped T<sub>90</sub></b>	< 30 seconds < 10 seconds				
<b>Measuring interval</b>	User programable: 0 to 10 minutes Resolution: 1 second steps				
<b>PID lamp lifetime</b>	Up to 10000 hrs from date of delivery <sup>[1]</sup>				
<b>User Interface</b>					
<b>General</b>	Graphical display with backlight, magnetic keys				
<b>Display Screen</b>	OLED high contrast white on black				
<b>Display Resolution</b>	128 x 64 pixels				
<b>Screen Size</b>	35 mm (w) x 17.5 mm (h)				
<b>Status Interface</b>	Tri color (RED, AMBER, GREEN) visible up to 20 meters away				
<b>Sensor</b>					
<b>Type</b>	MiniPID2				
<b>Sensor certification</b>	ATEX/IECEX: II 1G Ex ia IIC Ga Baseefa 07ATEX0060U				
<b>Environmental</b>					
<b>Operating Temperature:</b>	-40 °C to 50 °C (-4 °F to 122 °F) (Diffused) -20 °C to 50 °C (-40 °F to 122 °F) (Pumped)				
<b>Operating Humidity:</b>	0 to 100 %RH (condensing)				
<b>Storage Temperature</b>	-40°C to +60 °C (-40 °F to 140 °F)				
<b>Ingress Protection</b>	Main Unit: IP65 Sensor Head: IP65				

<b>Electrical</b>	
<b>Nominal Voltage</b>	8 V to 40 VDC (Powered from Safety Extra-Low (SELV))
<b>Maximum Current</b>	1.0 A at 8 V 0.2 A at 40 V
<b>Maximum Power</b>	8 W
<b>Typical Power</b>	2 W (depending on the LED intensity)
<b>Supply Cables</b>	0.5 to 2.5 mm <sup>2</sup>
<b>Maximum Contact Load</b>	60 VDC / 2 A 50 VAC / 2 A
<b>Current Loop: Internal Voltage 4 - 20mA External voltage</b>	19 V ± 1 V / 170 mA 8 V to 28 V
<b>Fuse</b>	Fuse T 1 A (blow value 35 A)
<b>Relay</b>	2 x SPDT (configurable NO & NC options)
<b>Relay Power</b>	60 VDC / 2 A or 50 VAC (2 A max load)
<b>Analogue output</b>	Current loop 4-20 mA and 0-5 mA
<b>Digital interface</b>	RS 485 Modbus
<b>Pumped Flow Rate</b>	260 cc/min
<b>Mechanical Interface</b>	
<b>Dimensions (H x W x D)</b>	<b>Diffused:</b> 223 x 170 x 115 mm (8.78 x 6.69 x 4.53 in) <b>Pumped:</b> 325 x 170 x 115 mm (12.80 x 6.69 x 4.53 in) Note: With cable glands, instruments width becomes 192 mm (7.56 in).
<b>Cable glands</b>	M25 x 1.5 Ex D (Cable diameter 13 to 18 mm).
<b>Mounting points</b>	2 x M8
<b>Weight</b>	Diffused: 2.5 kg Pumped: 2.9 kg
<b>General Specification</b>	
<b>Warranty</b>	1 year (standard) 2 years (extended) Lamp 1 year upon Ion Science Ltd approving the application set up <sup>[1]</sup> .
<b>EMC</b>	EMC Directive 2014/30/EU
<b>Certification</b>	ATEX/IECEX: II 2G Ex db ib IIC T4 Gb North American: Ex db ib IIC T4 Gb Class I, Zone 1, AEx db ib IIC T4 Gb

**All specifications quoted are at calibration point and under the same ambient conditions. Specifications are based on isobutylene calibration at 20 °C and 1000 mbar.**

<sup>[1]</sup> Lamp operation hours may vary depending on application and environmental conditions.

## Unpacking and inspection

All equipment shipped by Ion Science Ltd is packed in containers with shock absorbing filling to protect them against physical damage.

Remove the contents carefully and check them against the packing list. Report discrepancies between the contents and the packing list to Ion Science Ltd. Ion Science will not be responsible for discrepancies not reported within ten days of your receipt of the shipment.

Every FALCO (new units and those returned from a Service Centre) must have a Certificate of Calibration before you install it.

Upon removing your new FALCO 2 11.7 from its packing, you should have the following items:

### Diffused Unboxing:

<ul style="list-style-type: none"> <li>FALCO 2.1 with MiniPID2 and lamp and RJ45 cable fitted*</li> </ul>	
<ul style="list-style-type: none"> <li>Magnetic Pencil (part no. 873202)</li> </ul>	
<ul style="list-style-type: none"> <li>Calibration adapter (part no. A-873201)</li> </ul>	
<ul style="list-style-type: none"> <li>MiniPID removal tool (part no. 873250)</li> </ul>	
<ul style="list-style-type: none"> <li>Mini PID Electrode Stack Removal Tool (part no. 846216)</li> </ul>	
<ul style="list-style-type: none"> <li>2 x M20 cable entry glands (part no. 28733)</li> </ul>	
<ul style="list-style-type: none"> <li>Falco 2 Safety Notice Document</li> </ul>	
<ul style="list-style-type: none"> <li>Falco 2 Extended Warranty Document</li> </ul>	

\*RJ45 cable to be removed from instrument before install.

### Pumped unboxing:

<ul style="list-style-type: none"> <li>FALCO 2.2 with pump, MiniPID2, lamp and RJ45 cable fitted *</li> </ul>	
<ul style="list-style-type: none"> <li>Magnetic Pencil (part no. 873202)</li> </ul>	
<ul style="list-style-type: none"> <li>Hydrophobic Filter 50mm female luer to 1/4" barb (part no. A-873273)</li> </ul>	
<ul style="list-style-type: none"> <li>MiniPID removal tool (part no. 873250)</li> </ul>	
<ul style="list-style-type: none"> <li>Mini PID Electrode Stack Removal Tool (part no. 846216)</li> </ul>	
<ul style="list-style-type: none"> <li>2 x M20 cable entry glands (part no. 28733)</li> </ul>	
<ul style="list-style-type: none"> <li>Falco QSG - Hydrophobic Filter Instruction</li> </ul>	
<ul style="list-style-type: none"> <li>Falco 2 Safety Notice Document</li> </ul>	
<ul style="list-style-type: none"> <li>Falco 2 Extended Warranty Document</li> </ul>	

\*RJ45 cable to be removed from instrument before install.

## System Description

### Outputs and Communications

FALCO 2 has six communication outputs:

- The on-board LCD and LEDs on the faceplate
- 4-20 mA Current Loop
- RS 485 Modbus
- Two programmable relays
- Real-time information from the instrument is displayed on the LCD and transmitted on the 4-20 mA and RS 485 channels.

You can program two alarms to operate at a chosen concentration of gas. The alarms will display a message on the LEDs, energize the relays, and transmit a signal on the 4-20 mA channel.

The alarms and relays are individually programmable to the settings required by the site policy. You can choose either alarm to energize either relay.

Both relays can be programmed to switch 60 VDC / 2 A or 50 VAC / 2 A maximum load.

### RS 485 Modbus Interface

The FALCO Modbus interface uses Modbus RTU

- 9600 baud, 8 data bits, no parity, 1 stop bit.
- Instrument factory default Modbus slave ID: 100.
- Supported commands:
  - 03 Read Holding Register
  - 06 Write Single Register







Register Address	Name	R/W	Data Type	Range	Default Value	Description	QTY
001	Error	R/W	Integer	0 to 255	-	Error bits: pump blocked, expander error, low flow, etc.	1
102	Gas concentration	R	32-bit Float	$\pm 1.175494 \times 10^{-38}$ to $\pm 3.402823 \times 10^{+38}$	-	In ppm or mg/m <sup>3</sup> as per instrument setting	1
106	Sensor Voltage(mV)	R	32-bit Float	$\pm 1.175494 \times 10^{-38}$ to $\pm 3.402823 \times 10^{+38}$	-	Sensor voltage in mV	1
108	Temperature (°C)	R	16-bit Signed Integer	-32768 to +32767	-	Actual VOC sensor temperature x10, units °C	1
182	LED Brightness	R	16-bit unsigned Integer	0 to 100	-	LED Brightness (0-100%)	1
1005	Measurement Unit	R	Character	'p' or 'g' (Default value 'p')	p	Unit 'p' - ppm; 'g' - mg/m <sup>3</sup>	1
1010	Response Factor 1	R/W	32-bit Float	$\pm 1.175494 \times 10^{-38}$ to $\pm 3.402823 \times 10^{+38}$	1	Responds Factor	1
1012	Sensor Range	R	16-bit unsigned Integer	10/50/200/1000/3000	-	Instrument Sensor range in ppm	1
1013	_Alarm_1_level	R/W	integer	0-65535	50	VOC alarm 1 setpoint (no decimals, ppm)	1
1060	Span 1 Cal point	3 - Read Holding Registers	16-bit unsigned Integer	0 to 65535*	1	Calibration gas low concentration in ppm x10	1

\*Results that are x10 need to be divided by 10 to convert them to the correct decimal result.

### Modbus Error Status Bit Mask Explanation:

The instrument reports error statuses via a single Modbus holding register (Register Address 1). This register is an 8-bit integer where each bit represents a specific error condition on the instrument. A bit set to 1 indicates the corresponding error is active.

### Error Register Bit Assignments

Bit Position (0-7)	Bit Mask (Decimal)	Error State on Screen	Error Description	System
7 (leftmost)	128		The analogue to digital converter has stopped working	Pumped & diffused
6	64		The lamp is not lit during a measurement cycle or PID is not installed	Pumped & diffused
5	32		Flow System Blocked	Pumped Only
4	16		Analogue to digital converter has stopped working	Pumped & diffused
3	8		Low System Flow Rat	Pumped Only
2	4		If error 3 occurs, the Falco's lamp hasn't struck	Pumped & diffused
1	2		Reserved	
0 (rightmost)	1		Reserved	

## Interpreting the Error Register Value

- The Modbus register value represents a combination of active errors as a bitwise sum of their individual bit mask values.
- For example, a register value of 40 decimal (binary 00101000) indicates the following active errors:
  - Bit 5 (32): Low Flow
  - Bit 3 (8): ADC Error

## Usage Notes

- When reading this register via Modbus, apply bitwise operations to the value to determine which errors are active.
- Multiple errors can be reported simultaneously as bits can be set concurrently.
- This bit mask allows efficient communication of multiple errors in a single register.

## Installation Requirements

Please make sure you understand all the installation requirements and have read the technical specification before you install FALCO 2.

## Location Requirements

There are many variables involved in defining the optimum location for a gas detector.

Mount the FALCO 2:

- In a location where it is most likely to detect the gas, mindful of the target gases propensity to disperse in ambient atmosphere proportionate to weight.
- In an area that has good air circulation. Restricting natural air current can result in delayed detection.
- On a solid, stable support, where it is accessible for service.
- In a vertical position, with the sensor at the bottom to help avoid rain and dust entering the sensor chamber.
- Not in direct sunlight or over a heat source (this can cause the Falco to exceed its certified internal working temperature of 50 °C).
- Not in areas likely to flood.
- In a location that has easy access for servicing.
- For further guidance please consult the relevant local standards or local occupational health representatives.

### INFORMATION



- If the VOCs being detected are known to be lighter than air install the FALCO instrument as high on the wall as is practical.
- If the VOCs being detected are known to be heavier than air, install the FALCO instrument as low as possible but never on the floor.

## Power Requirements

Nominal Voltage: 8 V to 40 VDC

## Cable and Gland Requirements

We recommend you use screened cables e.g., multicore cable with SWA armor, or Braid Armor to protect against EMI.

The cable glands supplied with the Falco are EBU2MBNC M25x1,5 Ex D (Cable diameter 13 to 18 mm)

The manufacture and build of the cable glands are the responsibility of the installer. The cable glands must conform to the certification standards required for the installation site. Install blanking plugs with the appropriate certification standards to unused cable gland ports.

## National Pipe Tapered Thread

For applications that National Pipe Tapered Thread (NPT)  $\frac{3}{4}$  inch is required ION Science recommends the use of the following with certifications for use in Class I/II/III Division 1 and Zone 1,21 (according to international standards such as UL, CSA, ATEX, IECEx):

**RST** RX744974 (<https://www.rst.eu/en/products/accessories/produkt/erweiterungen-reduzierungen-metall-1/rx744974-1>)

**AXIS** TQ1917 (<https://www.axis.com/products/axis-tq1917-adapter-m25x15-34-npt>)

NOTE: The external terminal is to be used to ground / earth the FALCO 2 11.7 instrument. The connecting wire must be a minimum of 4 mm<sup>2</sup>.

## Installation



### INFORMATION

Before installing the FALCO instrument thoroughly read the technical specification contained in this User Manual

## Preparation for Installation

Before you install the FALCO, refer to the:

- Instrument User Manual
- Location Requirements
- Power Requirements
- Cable and Gland Requirements
- Dimensions for Installation
- RS485 Interface Requirements

NOTE: FALCO is supplied with a supportive stand. Remove the supportive stand before you proceed with installation. Support stand on pumped (FALCO 2.2) units only.

### Dimensions for Installation

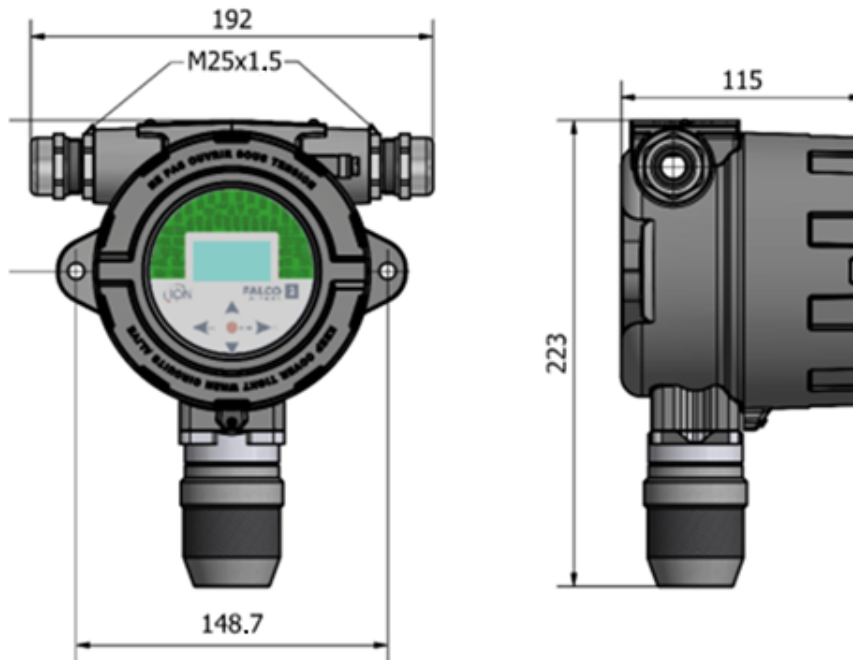

Figure 1 - 2 Falco 2.1

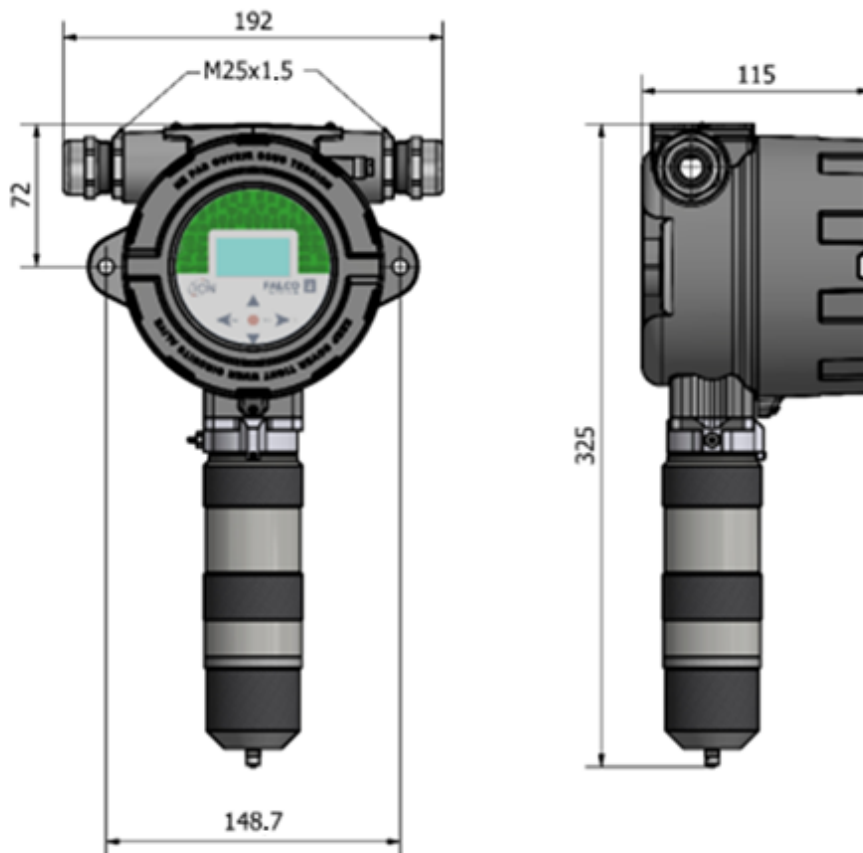

Figure 2 - Falco 2.2 with Pump

\*Dimensions in mm

## To Install the Housing Module

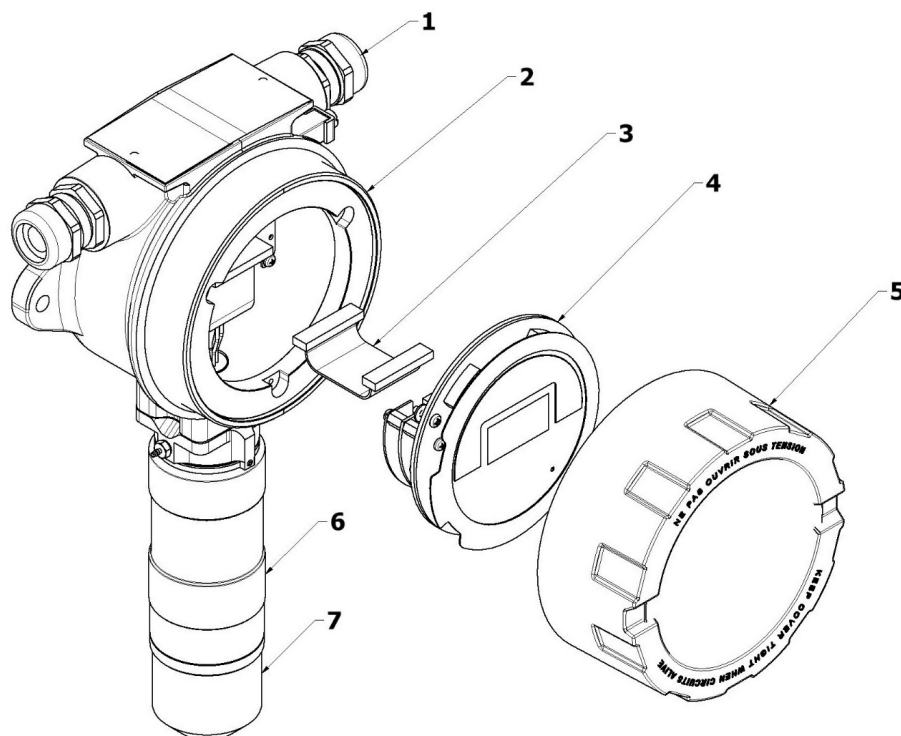

Figure 3 - exploded view of the Falco 2

Ref	Description
1	ExD Cable Gland
2	ExD Housing Module
3	Ribbon Cable
4	Control Module
5	Front Housing Cover
6	Pump Housing Cover
7	PID Housing Cover

To install the FALCO as a complete assembly:

1. Remove the FALCO supportive stand supplied with the instrument.
2. Use two M8 screws to install the FALCO as a complete unit (Main Unit and Sensor Housing together) on a solid, stable support.
3. After you install the FALCO, unscrew and remove the Front Cover. Unbolt the three bolts holding the control module (4) from the ExD Housing Module (2). Disconnect the Control Module from its Ribbon Connector to get access to the terminal blocks.
4. Feed the cables through the glands (1) and make the connections to the terminal blocks as you require. Refer to Configurations of the current loop, on the following pages.
5. Seal the cables in the cable glands.
6. Reconnect the Control Module to the Ribbon Connector and place into position. Replace and tighten the three retaining bolts.
7. Screw the Front Cover back on.
8. Connect and switch on the power supply.
9. Do an After-Installation Test.
10. Calibrate the instrument.

## After-Installation Test

Do a test of the relay and the 4–20 mA systems to check for correct installation and function.

Do a "Bump Test" to verify that the sensors respond correctly to the test gas at the concentrations programmed for Set Points 1 and 2.

A "Bump Test" does not calibrate the sensors. If the instrument does not display the gas concentration given by the bottle, do a calibration to give the correct readings.

## Installation in Zones with Explosive Atmospheres

The wiring diagram for the Falco is shown below, that covers in input power, MODBUS and Current Loop. There are four possible configurations for the 4–20 mA current loop depending on the installation site that are following section.

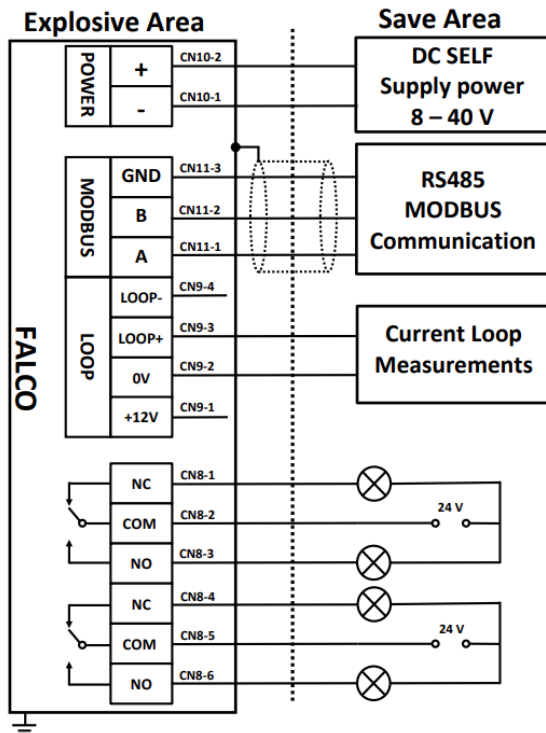

Figure 4 - showing typical connector wiring diagram

### Example method of connection for explosive environment

## Configurations of the 4–20 mA Current Loop

The Falco features a 4-20 mA current loop output, supporting signals within the standard 4 to 20 mA range. It includes an internal power supply and current source to accommodate various installation requirements. Depending on the site specifics, multiple configuration options are available. Please refer to the following block diagrams and DIP switch settings to select the most suitable configuration (found near the ribbon cable and is labelled 4-20 mA LOOP). All configurations are galvanically isolated from the 8 to 40 VDC power supply used to power the Falco instrument. For fault conditions, the current loop signal can be set to indicate faults by dropping to 3.25 mA or rising to 20.5 mA, depending on the instrument's fault scaling setup (see [4–20 mA Fault scaling]).

Configuration when using internal power supply connected to the current source.

This DIP switch can be found near the ribbon cable and is labelled 4-20 mA LOOP.

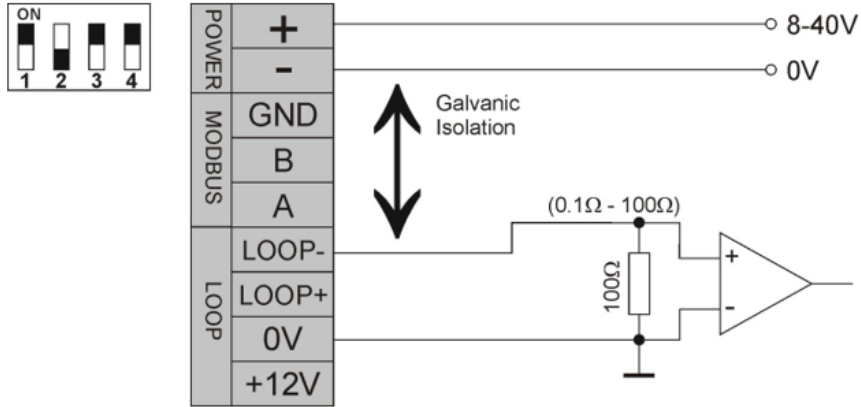

Figure 5 - Falco Current Loop Configuration 1 – active current loop, using internal power supply connected to the current source.

Passive current loop configuration when using externally powered current source:

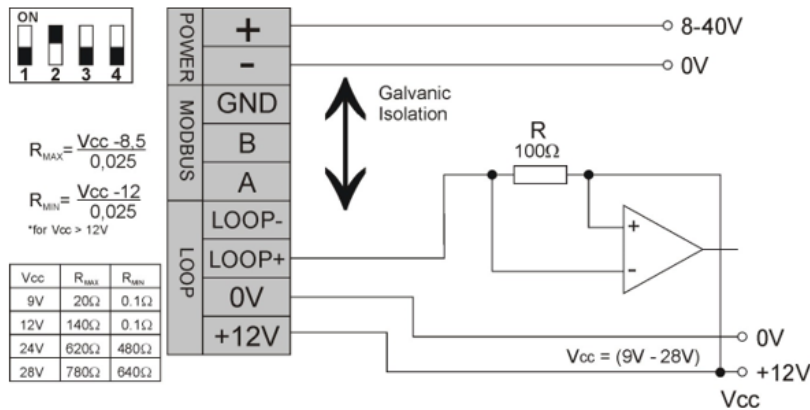

Figure 6 - Falco Current Loop configuration 2 – passive current loop, externally powered current source.

When using this configuration ensure that the current loop circuit has voltage is between 8.5 V and 12 V, at Loop + after the resistances of the line have been taken into consideration.

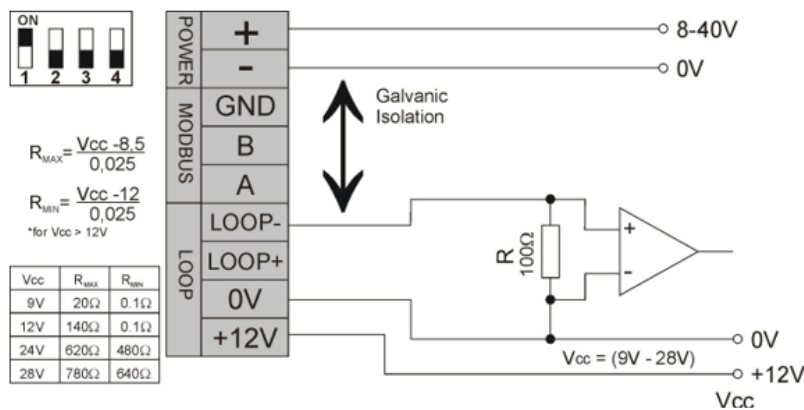

Figure 7 - Falco Current Loop Configuration 3 – passive current loop, externally powered current source.

When using this configuration ensure that the current loop circuit has voltage is between 8.5 V and 12 V, at Loop + after the resistances of the line have been taken into consideration.

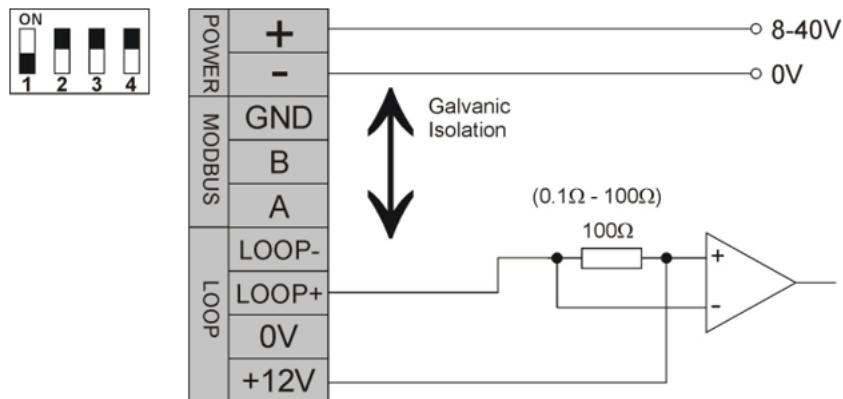

Figure 8 - Falco Current Loop Configuration 4 – active current loop, using internal power supply connected to the current source.

## Calibrating the 4 – 20 mA

To calibrate the 4–20 mA on the Falco 2 you will need to access the i5 menu (see **Navigating the Menus and Selecting Menu Options** for instructions how to access the i5 menu).

### 4–20 mA setup

Below shows the basic setup for being able to calibrate the 4–20 mA on the Falco 2 instrument. Ensure the instrument is not powered whilst making any connections.

Included parts:

- Magnetic pencil (part no. 873202)
- Instrument

#### Additional Equipment required:

- 0.5 to 2.5 mm<sup>2</sup>
- Leaded resistor ±1 % or better
- Multimeter with mA range recommended ±1% 2 digit accuracy or better.
- Multimeter leads with crock clip or probes (depending on method of calibration)

While the wire itself introduces resistance that causes a voltage drop in the system, it is normally not a concern, as the voltage drop in a section of wire is small. However, over long distances, it can add up to a significant amount, depending on the wire's diameter. Therefore, for long cable runs, it is recommended, if possible, to place the multimeter at the end of the cable run to account for this or to use an equivalent resistance at the base of the instrument to ensure accurate calibration.

There are two main calibration methods: basic and voltage.

### Basic Method

When making connections, ensure the instrument is not powered. Use appropriate multimeter leads connected to the **COM** and **mA** inputs on the multimeter to the CN4-9 labelled Loop- and CN9-2 labelled 0 V on the instrument, as shown in Figure 9. Set the multimeter to the mA range and to DC measurement.

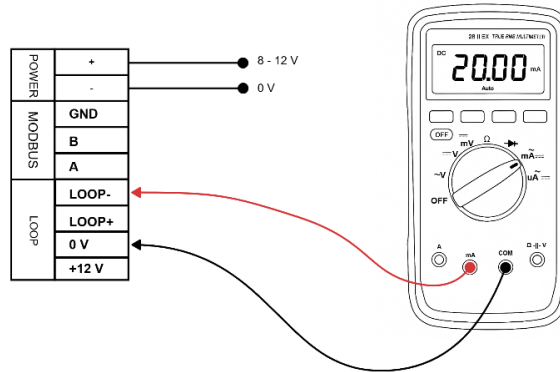
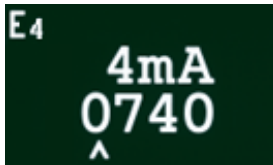

Figure 9 - 4 - 20 mA calibration setup with multimeter

Power the instrument on and allow it to load, to skip the warmup use the magnetic pen to press the enter **●** to skip the warmup procedure. Now press the Right **▶** key to move to the next menu, when on the i5 menu hold the magnetic pen on the enter **●** to activate the menu by displaying the will then show a **▣** cursor displayed next to the first option in the current menu.

Use the **▼** to scroll down to the 4 mA calibration **E4** menu press the enter **●** to enter the calibration setup. The multimeter should now display 4.00 mA. If the multimeter is not showing 4.00 mA use the Right **▶** key to move to the value that needs to be adjusted and the **▲** and **▼** to adjust up or down until the multimeter reads 4.00 mA.



### Cable Resistance Consideration for 4–20 mA Calibration

While the wire itself introduces resistance that causes a voltage drop in the system, it is generally negligible over short lengths. However, over long distances, the cumulative voltage drop can become significant, depending on the wire diameter used.

### 4–20 mA Fault scaling

In mA Fault scaling, the user can set the Alarm points to be below four mA or above 20 mA. As shown in the table below (see Menu i5 for set-up).

Error	mA reading when set to <4 mA	mA reading when set to >20 mA
Err1	3.25 mA	20.5 mA
Err2		
Err3		
Err4		
Err5		
Err6		

## Hydrophobic Filter

It is very important to prevent the ingress of water and moisture into the Falco as this can cause damage to the PID sensor and electronic circuits. Please ensure that before running Falco you have attached a hydrophobic filter to the instrument. The Luer is factory fitted to the Falco. The hydrophobic filter is then attached to the Luer, please ensure the hydrophobic filter is fitted to the Luer the correct way round (see image below). The hydrophobic filter must always be fitted and will need to be replaced on a periodic basis.

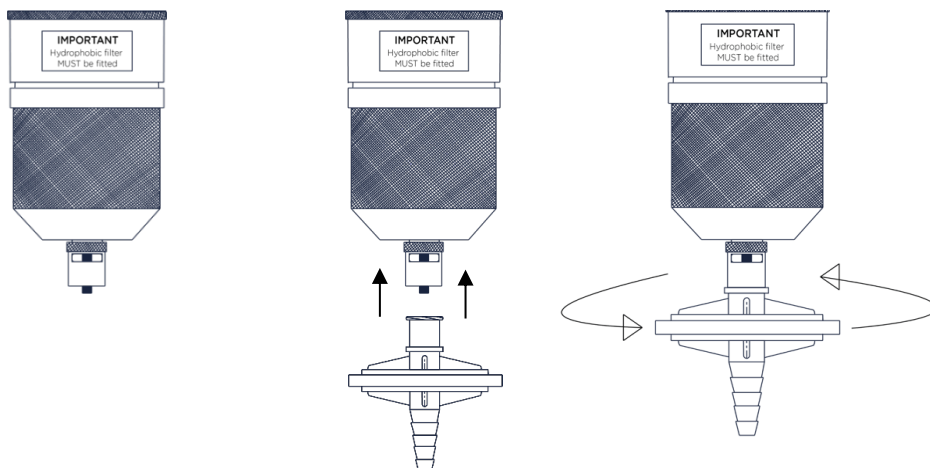

## Sampling Tube Length

The maximum recommended sample tube length is 20 m (4 x 2 mm tube).

**Sample tubing should be made of stainless steel or fluorinated material e.g., PTFE, PVDF. This prevents VOC's "Sticking" to the inside walls of the tubing and causing false readings.**

## Removal of the Control Module

The removal of the Control Module will only be necessary if the module is no longer required in its detecting position or if there is a module malfunction. The FALCO has an externally located intrinsically safe sensor, allowing for quick and easy servicing without the need for a hot work permit. Dual certification allows the FALCO to be serviced and calibrated in a hazardous environment without having to remove the power.

## To Remove the Control Module

**CAUTION:** This area must be known to be free of flammable concentrations prior opening the enclosure

To remove the FALCO as a complete assembly:

1. Switch off and isolate the power to the FALCO.
2. Unscrew and remove the Front Cover.
3. Unbolt the three retaining bolts on the Control Module.
4. Disconnect the Control Module from the Ribbon Connector and remove it.
5. Unseal the cables in the cable glands.
6. Disconnect the cables from the terminal blocks and withdraw them from the Housing Module via the cable glands.
7. Make sure that all the electrical connection is either removed or left in a safe, isolated condition.

## Operating the FALCO

### User Interface



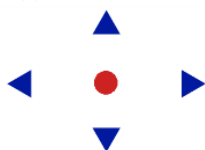

The FALCO front face has:

- OLED display
- Keypad - 5 magnetic keys
- Status Light

#### Keypad





For easy menu navigation the keypad consists of five magnetic keys **Up**, **Down**, **Left**, **Right** and **Enter**.

Up and Down		Moves the cursor (indicating which screen option is currently selected) and adjusts numeric values and settings up and down.
Left and Right		Moves the cursor left and right and steps between menu screens.
		Left is also used to “escape” settings screens (e.g. exit a menu or sub-menu).
Enter		Used to enter features (e.g. settings screens) and to confirm specified settings.





#### INFORMATION

The Enter  key, and the Left  key when being used to escape, must be pressed and held briefly to operate them.

The other keys, and the Left key when not been used for escape only need to be tapped.

### Status Light

Yellow	Displayed during start-up only, when power is first applied.
Green	Indicates that FALCO is operating correctly. Also displayed during the start-up routine.
Amber	Flashing amber indicates Alarm 1  has been triggered i.e. the measured level of VOC is above the alarm threshold. Also displayed during the start-up routine.
Red	Flashing red indicates Alarm 2  has been triggered, i.e. the measured level of VOC is above the alarm threshold. Also displayed during the start-up routine.



#### INFORMATION

The % brightness of the LEDs during normal operation and when alarms are being triggered is configurable. There are separate settings for both conditions.

## Start-Up Routine

When power is applied, the Status Light goes yellow.

The FALCO will then display the following screens, in this order:

### Logo Screen



After the power is turned on, the FALCO displays the 'Ion Science' logo for 3 seconds and the status light is green.

### Info screen 1

Info screen 1 then appears for 3 seconds. It displays the following:



PC - Modbus address  
RF - Response factor  
FW – Instrument firmware version  
FW – Sensor firmware version

The status light goes amber.

### Info screen 2

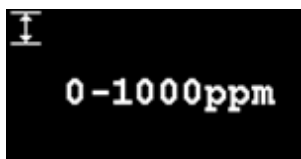

The Info screen 2 then appears for 3 seconds showing the instrument measurement range. The status light goes red.

### Warm-up

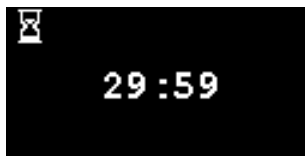

The warm-up screen then appears, and the screen shows the 30 minute countdown. The status light goes green.



#### INFORMATION

After switch-on the instrument should be allowed to acclimatize for 30 minutes before working in its 'Normal running mode'.

The warm-up time can be skipped by pressing the **Enter**  key.

## Normal Running Mode Screen

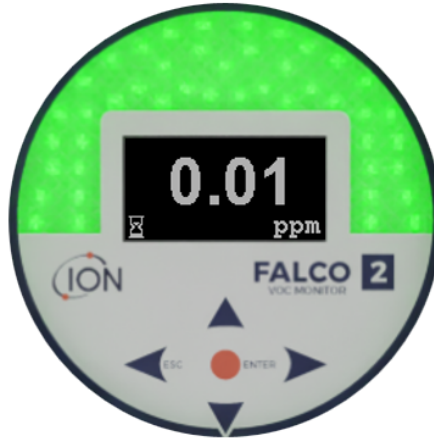

The screen then appears continuously and shows the PID reading and units. The Status Light color depends on the status.



### INFORMATION

The hourglass symbol will appear on the screen for the remaining 'warm-up' time if it has been skipped. The brightness of the display will also slowly pulsate to indicate that the warm-up period has been skipped.

## Software Screens

There are eight menus: **i1, i2, i3, i4, i5, i6, i7 and i8**

## Software Flow Chart



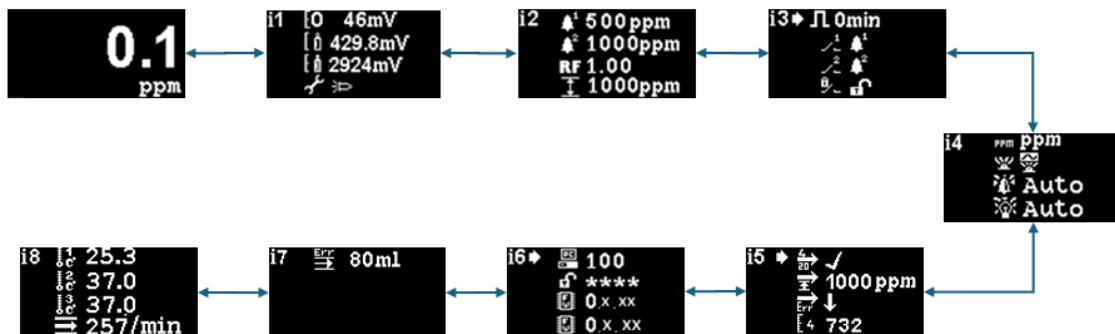

To access the settings menus, press the **Right** key from the normal running mode screen. If a passcode has been set, the lock screen will be displayed. Otherwise, the **i1** menu will be displayed. To go back a screen in the menu, use the **Left** key to return to the home screen.



## Lock Screen



The Lock screen is displayed if a password number has been specified (see menu **i6**). It protects the instrument from unauthorized adjustment - the menus (see below), cannot be accessed until the correct number has been entered.

Press the **Enter**  key. A cursor  is then displayed under the first asterisk. Press the **Up**  or **Down**  key. The asterisk will be replaced by a number. Keep pressing the up and down keys until the first digit of the passcode is displayed.

Press the **Right**  key to move to the next asterisk. Repeat the above procedure to enter the next digit. Repeat until the four digits of the password are entered.

Press the **Enter**  key. If the correct password was entered, the **i1** menu will be displayed.

If not, the LED status indicator will change to red. The Lock screen remains displayed, and the user can attempt to enter the password again.



### INFORMATION

Entering 4321 at the Lock screen will always enable access to the menus. This can be used if, for example, the actual password has been forgotten.

## Navigating the Menus and Selecting Menu Options

The six screens are navigated through using the left and right  keys on the magnetic keypad. For example, if the **i2** menu is being displayed, press the left key to display the **i1** menu and the right key to display the **i3** menu.

Each of the menu screens has two or more options on it.

To activate the menus, press the **Enter**  key. A  cursor is then displayed next to the first option in the current menu.

To select a menu option, use the **Up**  and **Down**  keys to move the cursor to the required option. To enter the required option, press the **Enter**  key.

See below for details of all the menus, sub-menus and options.



### INFORMATION

If no action is taken in the menu screens for 120 seconds, the display will automatically revert to the Normal Running Mode screen. If a passcode has been set, this must again be entered to access the menus.

### Menu i1



This menu displays the following options, along with their current settings:



**Zero:** Used to set the Zero gas calibration level. The currently set level (in mV) is displayed.



**Span 1:** Used to set the Span 1 gas calibration level. The currently set level (in mV) is displayed.



**Span 2:** Used to set the Span 2 gas calibration level. The currently set level (in mV) is displayed.



**Service / Test mode:** Used to switch to the MiniPID sensor in and out of servicing mode. When service mode is selected the power to the MiniPID is turned off. The current setting is indicated by a symbol. indicates the MiniPID is off, indicates the MiniPID is on. From here you can also put the Falco into test mode. This means the Falco will simulate its output behaviors. To configure the Falco to display a fixed output level, select . To set the Falco to output a sawtooth wave, select .

### Menu i2



**Alarm level 1:** Used to set the ppm level at which Alarm 1 is triggered. The current level is displayed.



**Alarm level 2:** Used to set the ppm level at which Alarm 2 is triggered. The current level is displayed.



**Measurement range:** Used to view the detection range of the instrument.



**Response factor:** Used to set the response factor appropriate for the gas to be detected. The current factor is displayed.

### Menu i3



**Measurement Cycle:** This allows you to change the time between updating outputs.



**Relay 1 output:** The instrument has two relay outputs, both of which can be triggered by a condition selected by the user. The condition that triggers Relay 1 is selected via the Relay 1 output option. A symbol representing the currently selected trigger condition is displayed (see the Relay section for more information).



**Relay 2 output:** See above.

Relay Latching: Configures the relay to be latching.

### Menu i4



- Detection units:** Used to change the detection units from the default of ppm to mg/m<sup>3</sup>. The current units are displayed.
- PID status light mode:** Used to switch the status light between steady illumination and slow pulsing when alarming. The current setting is indicated by a symbol.
- Alarm brightness:** Used to set the brightness of the status light during alarm conditions.
- Status Light brightness:** Used to set the brightness of the status light during normal operation.

### Menu i5



- 4-20 mA Enable/Disable:** Used to set the 4 mA to 20 mA output to be active or inactive, as indicated by a tick or a cross.
- 20 mA range:** Used to set the 20 mA range of the instrument.
- 4-20 mA fault level:** Used to set whether the fault signal is <4 mA or > 20 mA (see 4–20 mA Fault scaling for fault mA signal levels).
- 4 mA Calibration:** Used to set the 4 mA calibration
- 20 mA calibration:** Used to set the 20 mA calibration

### Menu i6



- Modbus address** – Used to select a Modbus slave address.
- Password lock** – Used to set the password lock on and off, and to change the password number. The symbol for this option indicates whether the lock is on or off .
- Firmware version** – Displays the instrument's current firmware version.

### Menu i7

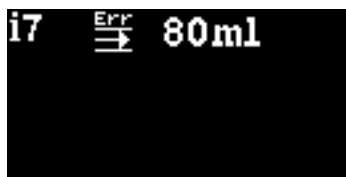

**Flow Error Setpoint** - The flow level (in ml/min), below which the unit will raise an error.

**Note:** Do not change below 80 ml.

### Menu i8

The i8 menu displays the temperature of the internal flow sensor system. The flow temperature and flow are only used for pumped systems and default to 0 on diffused FALCO 2 instruments.

#### Diffused instrument

	<b>Flow Sensor </b> - No applicable
	<b>Flow Sensor </b> - No applicable
	<b>Flow Sensor </b> - No applicable
	<b>Pump Flow rate </b> - No applicable

#### Pumped Instrument

	<b>VOC Sensor </b> - Temperature of the VOC sensor
	<b>LED Sensor </b> - Temperature of the LED sensor
	<b>Flow Sensor </b> - Temperature of the internal flow sensor system.
	<b>Pump Flow rate </b> - ml/min

### Pump Operation

The pump will operate automatically and does not need to be configured by the user.

The Falco has a built-in flow measurement system that governs the pump flow rate. To establish an accurate flow rate, the pump will briefly stop every 30 seconds so that the flow measurement system can establish an accurate baseline, this is called the flow measurement cycle.

If the flow measurement system detects that the flow rate is less than 80 ml/min the instrument will display Error code 4 (Low System Flow). On Falco 2 this can be set by the end user in this screen. If the error persists for more than 3 flow measurement cycles, the instrument will display Error code 6 (Flow System Blocked).

## Calibration

Calibration is essential to ensure the accuracy and reliability of your Falco 2 instrument in monitoring volatile organic compounds (VOCs) in your environment. Regular calibration aligns the instrument’s readings with known gas concentrations, helping maintain correct operation, meet safety requirements, and comply with recommended maintenance schedules. The following section explains the calibration procedure, equipment requirements, and recommended practices to achieve optimal instrument performance.

Detection Range (ppm)	Calibration Points	Recommended Calibration Gas Concentration
0–10	2-point (Zero, Span 1)	Near alarm level, within instrument range
0–50	2-point (Zero, Span 1)	Near alarm level, within instrument range
0–50 (TAC)	2-point (Zero, Span 1)	Near alarm level, within instrument range
0–1000	3-point (Zero, Span 1, 2)	Near alarm level, within instrument range
0–3000	3-point (Zero, Span 1, 2)	Near alarm level, within instrument range

*Note: For optimal accuracy, select a calibration gas concentration close to the alarm setpoint, rather than using a fixed value, unless otherwise recommended for your specific application. This ensures the calibration better matches actual operating conditions.*

Before starting the calibration process, please ensure you have the following equipment ready for use.



- Magnetic Actuator (part no. 873202)
- Hydrophobic Filter (part no. A-873273) (pumped version only)
- Demand Flow Regulator (part no. 5/RD-01) (pumped version only)
- Filter Disc (part no. 873210) (diffused version only)
- Fixed Flow Regulator (part no. 5/RP-04) (diffused version only)
- Zero air
- Span gas
- Suitable tubing to connect gases to Falco

**The calibration options are accessed from Menu i1 as shown in Navigating the Menus and Selecting Menu Options**

### Zero

- 1) **Local ambient air can be used for zeroing if it can be confirmed there are no target or interference gases present in concentrations exceed the lower detection limit of the Falco. If this cannot be**



*confirmed zero air should be used. If using a cylinder attach the tubing between the Falco and the gas regulator.*



- 2) Enter zero Cal mode by moving the cursor to the zero Cal icon  and then press the Enter  key. The zero Cal screen is described below:



The top value is the live ppm reading from the Falco (based on previous calibration)

The bottom number indicates this is the zero-cal screen

- 1) The live reading will move towards zero as the sensor housing is purged. After 2 minutes, press the Enter  key to set the zero level.  
The Status Light will then blink briefly to confirm the setting has been made. The top reading will then change to 0.0ppm.
- 2) Remove the Zero air
- 3) Press the  button to exit zero mode.

NOTE: The cursor cannot be moved from next to the “set” symbol . The only function the user can carry out is to press the Enter  key to set the zero level to the current ppm reading.

### Span 1

*Span 1 is used to calibrate Span 1 of the Falco 2.*



- 1) Attach the span gas cylinder to the Falco 2.



Enter Span 1 mode by moving the cursor to the Span 1 icon  and then pressing the Enter  key. The Span 1 screen is described below:





The top value is the live ppm reading from the Falco (based on previous calibration)

The lower value is the span 1 concentration (100.7ppm in this example).

If the Span 1 concentration is not the same as the calibration gas concentration, it must be changed. To change the Span 1 concentration, move the cursor  to the lower value and press the Enter  key. A new screen with that value is then displayed.

Change this value to match the level specified on the calibration gas bottle as follows. A cursor  is displayed under the first digit of the value. Press the Up  or Down  key to change it.

Press the Right  key to move to the next digit. Repeat the above procedure to change it as required.

Press the Enter  key to return to the previous screen (above). Then move the cursor to the “set” symbol  and apply the gas to the PID sensor. After 2 minutes press the Enter  key. The status light will ‘blink’ briefly to confirm the setting has been changed.

- 2) Remove the span gas cylinder.
- 3) Press the  button to exit span 1 mode.

## Span 2

Span 2 is used to calibrate span 2 of the Falco 2.

- 1) Attach the span gas cylinder to the Falco 2.
- 2) Enter span 2 mode by moving the cursor to the span 2 icon and then pressing the Enter key.

The span 2 screen is described below:



The top value is the live ppm reading from the Falco (based on previous calibration)

The lower value is the span 2 concentration (1000 ppm in this example).

If the span 2 concentration is not the same as the calibration gas concentration, it must be changed. To change the span 2 concentration, move the cursor to the lower value and press the Enter key. A new screen with that value is then displayed.

Change this value to match the level specified on the calibration gas bottle as follows. A cursor is displayed under the first digit of the value. Press the Up or Down key to change it.

Press the Right key to move to the next digit. Repeat the above procedure to change it as required.

Press the Enter key to return to the previous screen (above). Then move the cursor to the “set” symbol and apply the gas to the PID sensor. After 2 minutes, press the Enter key. The status light will ‘blink’ briefly to confirm the setting has been changed.

- 3) Remove the span gas cylinder.
- 4) Press the button to exit Span 2 mode.

## RF (Response Factor)

Response factor adjustment is accessed from Menu i2

PIDs are typically calibrated with isobutylene. However, not all VOCs have the same response. The difference in response can be accounted for by multiplying the reading by the VOCs response factor. If a response factor is applied, the concentration displayed on the Falco will represent the concentration of the VOC.

For example, if the RF is 00.50, and 100ppm is detected based on an isobutylene calibration:

100 ppm x 00.50 = 50 ppm is the value displayed

The default setting for the response factor is 1.

To set a response factor, move the cursor to the response factor icon and press the Enter key.

A cursor is displayed under the first digit of the value. Press the Up or Down key to change it.



Set the response factor by moving the cursor and changing the values.

If a factor of higher than 10.00 is entered, when the Enter key is pressed, the factor will revert to the default (01.00ppm) and the screen will not exit.

Note: The Modbus interface can transmit both the measured gas concentration and additional configuration parameters, such as the response factor (available at Modbus address 1010).

Note: The 4–20 mA analogue output only represents the measured gas concentration as set by the instrument (ppm/ mg/m<sup>3</sup>) and does not include the response factor or any other configuration data.

The factor can be adjusted from 0.10 to 15.00 in 0.01 increments.

## Detection Units

*The detection unit options are accessed from Menu i2*

Move the cursor  to the required units. Press the **Enter**  key to save the setting change and return to the **i4** menu. The status light will then blink briefly to confirm the setting has been made.

Press the **Esc**  key to return to the **i4** menu without saving the change to the setting.



Used to change the detection units from the default of ppm to milligrams per meter cubed (mg/m<sup>3</sup>).

The default units are 'ppm' and there is an option to display the readings in milligrams per meter cubed (mg/m<sup>3</sup>). To display the reading in mg/m<sup>3</sup> requires a barometric pressure and temperature value. The instrument assumes the fixed values shown below. \*

Barometric pressure: 1000 mbar

Temperature: 20 °C

\*Mg/m<sup>3</sup> readings are based on isobutylene as a calibration gas (molecular weight 56.106 g/mol.)

## Measurement Cycle

*The measurement cycle is accessed from menu i3.*



The measurement cycle can be set from continuous to 10 minutes with 1 minute increments

The default setting is 00 minutes, meaning that the display will update in real-time. This setting is adjustable in 1-minute increments:

**00 mins** = PID is illuminated permanently. Outputs updated 1/second.

**01 mins** = PID is illuminated permanently. Outputs updated 1/minute.

**02 mins** = PID is illuminated permanently. Outputs updated 2/minute.

**03 mins** = PID is illuminated permanently. Outputs updated 3/minute.

...and so on for the 04 mins to 10 mins settings.

## Alarms



*The alarm levels are set in menu i2*

*The Falco has two alarm levels, 1 and 2. When alarm level 1 is reached, the status bar will go amber and when Alarm 2 is reached, the status bar will go red.*

### Alarm 1



Used to set the ppm level at which Alarm 1 (amber) is triggered. When accessed, the screen displays the current level.

Set the level as follows. A cursor  is displayed under the first digit of the alarm level. Press the **Up**  or **Down**  key to change it.

Press the **Right**  key to move to the next digit. Repeat the above procedure to change it as required. Repeat until the required value has been entered.

Press the **Enter**  key to save the setting change and return to the **i2** menu. The status light will then blink briefly to confirm the setting has been made.

Note that the instrument will not allow the Alarm 1 level to be set above the Alarm 2 level.

Press the **Esc**  key to return to the **i2** menu without saving the change to the setting.

### Alarm 2



Used to set the ppm level at which Alarm 2 (red) is triggered. When accessed, the screen displays the current level.

Set the Alarm 2 level in the same way as described for Alarm 1 above.

Note that the instrument will not allow the Alarm 2 level to be set below the Alarm 1 level.

Alarm 1 will be superseded by the Alarm 2, i.e. if the level of organic compound detected exceeds the Alarm 2 level, that alarm will be triggered instead of Alarm 1 (even though the level will be above the Alarm 1 threshold as well).

## Alarm Brightness

*Alarm brightness is accessed from menu i4*

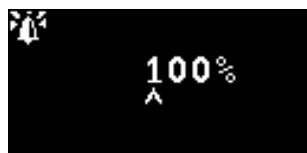

Used to set the brightness of the Status Light during alarm conditions, from 0 to 100% for green, and 50-100% for amber and red. "AUTO" brightness mode is selected by setting the brightness to 0%

Change the percentage brightness as required.

Alarm brightness may also be set to AUTO mode. Auto mode will measure the ambient light on the face of the instrument and adjust the brightness of the LEDs. The LEDs will become brighter if the instrument is in high LUX conditions (bright sunshine) and dimmer during low LUX conditions.

While on the screen, the Status Light will change to red and will change brightness in response to a change in brightness percentage.

If a brightness of higher than 100% is entered, when the **Enter**  key is pressed, the factor will revert to the default (100%) and the screen will not exit

## Alarm Pulsing

*Measurement cycle is accessed from menu i3*



Used to switch the LED display between steady illumination and slow pulsing

To change the setting, press the **Up**  or **Down**  key to change the setting. The symbol will change as appropriate:



Steady illumination.



Slow pulsing.

Press the **Enter**  key to save the setting change and return to the **i3** menu.

Press the **Esc**  key to return to the **i3** menu without saving the change to the setting.

## Relays

*Relay options are accessed from menu i3*

### Relay 1 Options



Used to specify which of 4 conditions will trigger the Relay 1 output. Each is represented by a symbol, as described below.

The following conditions may be selected from:



Activate when Alarm 1 is exceeded.



Activate when Alarm 2 is exceeded.



Activate when a fault condition is raised.



Activate for 1 second after the output is updated.

To change the setting, press the **Up**  or **Down**  key to browse through the 4 settings. The symbol will change as appropriate.

Press the **Enter**  key to save the setting change and return to the **i3** menu.

Press the **Esc**  key to return to the **i3** menu without saving the change to the setting.

### Relay 2 Options



Used to specify which of 4 conditions will trigger the Relay 2 output.

See the description of the Relay 1 options setting for details.

## 4-20 mA

4-20 mA options are accessed from menu i5

### 4-20 mA Enable/Disable



Used to turn the 4 mA to 20 mA output on and off.

To change the setting, press the **Up** or **Down** key to switch between on (tick symbol), and off (cross symbol).

Press the **Enter** key to save the setting change and return to the i5 menu.

Press the **Esc** key to return to the i5 menu without saving the change to the setting.

### 4 - 20mA Range



The lower limit of the 4 mA to 20 mA output range, mapped to 4 mA, is 0 ppm. This option is used to set the upper limit, mapped to 20 mA.

Change the value as required.

## Modbus Address

Modbus address setting is accessed from menu i5



Used to select a Modbus slave address.

Change the address number as required, from 1 to 247. The instrument default is address 100.

A unique slave address must be assigned for each Modbus slave device on your network.

## Status Light Brightness

*The Status Light brightness is accessed in menu i4*



Used to set the brightness of the Status Light during alarm conditions, from 0 to 100% for green, and 50-100% for amber and red. "AUTO" brightness mode is selected by setting the brightness to 0%

Change the percentage brightness as required.

Status light brightness may also be set to AUTO mode. Auto mode will measure the ambient light on the face of the instrument and adjust the brightness of the LEDs. The LEDs will become brighter if the instrument is in high LUX conditions (bright sunshine) and dimmer during low LUX conditions.

While on the screen, the Status Light will change to green (if it wasn't already) and change brightness in response to a change to the brightness percentage.

If a brightness of higher than 100% is entered, when the **Enter**  key is pressed, the factor will revert to the default (100%) and the screen will not exit.

## Service Mode

*Service mode is accessed from the menu i1*



Used to turn the service mode on and off.

The power supplied to the MiniPID sensor is not dangerous to the user by either the risk of electrocution or cause a threat of an explosion in a hazardous environment.

It is good practice to remove local power to circuitry when servicing to avoid possible damage from a short circuit.

A service mode setting that removes local power is therefore available and can be switched to and from using this screen.





The lamp symbol on the screen indicates whether the sensor service mode is on or off.

If the sensor is in normal mode  is displayed.

If the sensor is in servicing mode  is displayed.

If the instrument is in fixed output test mode  is displayed.

If the instrument is in oscillating output test mode  is displayed.

To change the setting, press the Up  or Down  key. The symbol will change as appropriate. Press the Up  or Down  key again to reverse the setting.

Press the **Enter**  key to save the setting change and return to the i1 menu.

Press the **Esc**  key to return to the i1 menu without saving the change to the setting.

See below for how to change these settings.



### INFORMATION

Alarm levels can be used to trigger relay 1 or relay 2 (see relay section below).

## Password Lock

Use this function to enable the password lock by setting a password that is not 0000.



The default password on the instrument is 0000 and will be shown on the display. When the password is set to 0000, this means the lock is off see **Menu i6** section for details.

The current password number will be displayed on the screen.

A cursor is displayed under the first digit of the value. Press the **Up** or **Down** key to change it.

Press the **Right** key to move to the next digit. Repeat the above procedure to change it as required. Repeat until the required password has been entered.

Press the **Enter** key to save the setting change and return to the **i6** menu. The status light will then blink briefly to confirm the setting has been made.

Note that the padlock symbol will now show locked as described in **Menu i6** section if the password is not set to 0000.

Press the **Esc** key to return to the **i6** menu without saving the change to the setting.

## Servicing

Item No	Image	Description	Part Number
1		MiniPID removal tool	873250
2		MiniPID Electrode Stack Removal Tool	846216
3		Falco Long Life Lamp (3.2V to 3.6V) 10.6eV	LA4SFL3.2
4		Falco Electrode Stack white with seal (50 and 3000ppm)	A-846627
		Falco Electrode Stack Orange with seal (50 and 3000ppm)	A-846627
		Falco TAC Electrode Stack white with seal (0-50ppm)	A-846767
5		MiniPID 2 Falco Orange	MP6SM6FOXU2
		MiniPID 2 Falco White	MP6SM6FWXU2
		MiniPID2 Falco TAC	MP6SXLFTXU2

## Filter Disc Replacement

The Filter Disc (part no. 873210) on diffused instruments only should be changed after every 100 hours of use, or sooner for particularly dusty or moisture laden environments. To avoid contaminating Filter Discs, they should only be replaced in a clean environment, using clean hands and equipment.

## Bump Test

The accuracy of the measurements can be easily checked at any time. ION Science recommends performing regular Bump Test on the FALCO 2 instruments to ensure the instrument responds correctly and that the alarm indicators activate properly when gas is detected at the specified alarm levels. Bump tests should also be conducted whenever these alarm levels are changed.

A calibration is recommended when the instrument response is close to or out of specification to detects and correct deviations, ensuring instruments provide reliable results.

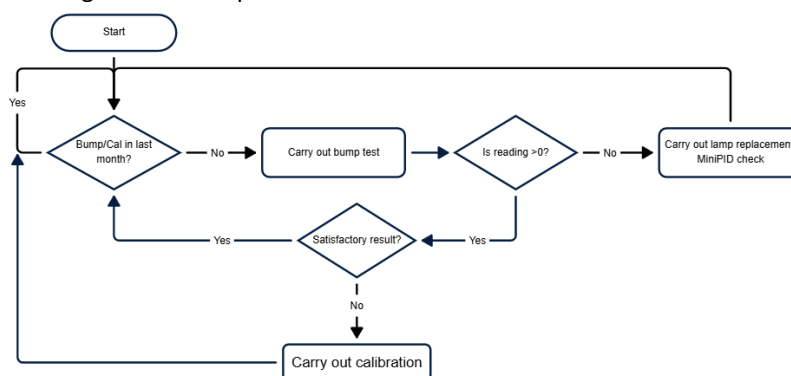

Figure 10 - Falco 2 recommended procedure for bump testing and calibration



### WARNING

Relays and the 4-20 mA current will continue to operate as per normal operation this may NOT equal current environmental conditions. This can lead to false alarms if precautionary measures are taken into consideration.

**Before starting the bump test process, please ensure you have the following equipment ready for use.**

- Magnetic Actuator (part no. 873202)
- Span gas
- Suitable tubing to connect gases to FALCO 2 calibration adapter (part no. A-873201)
- Fixed Flow Regulator (part no. 5/RP-04)
- Hydrophobic Filter (part no. A-873273) (pumped version only)
- Demand Flow Regulator (part no. 5/RD-01) (pumped version only)
- Suitable tubing to connect gases to Falco
- Filter Disc (part no. 873210) (diffused version only)
- Fixed Flow Regulator (part no. 5/RP-04) (diffused version only)

**Using the Span gas to verify the unit is within satisfactory reading (see speciation table for accuracy):**

- 1) Attach the span gas cylinder to the FALCO 2.
- 2) Verify the FALCO 2 display updates
- 3) If the displayed result is out of specification/satisfactory reading:
  - a. Carry out calibration procedure as detailed in Calibration section of this manual.
  - b. If no result shown on display when applying gas may be caused by the lamp not striking or PID is not installed. Follow section of this manual to replace Lamp or insert PID. For further help contact your local service center.

## Cleaning the MiniPID

FALCO has been designed to ensure servicing is quick and easy:

1. Before servicing FALCO, set the device to Servicing Mode.
2. Unscrew the Sensor Cover (1) to access the MiniPID (4) located in the Sensor Housing.
3. Remove the MiniPID (4) using the MiniPID removal tool (9). Be careful when withdrawing it, don't twist when the MiniPID is in the Sensor Housing. Only light force is required.



### CAUTION

Do not twist the MiniPID (4) while it is within the Sensor Housing.

4. Use the electrode stack removal tool to remove the electrode stack. Hold the MiniPID (4) upside down, the Electrode Stack (8) and PID Lamp (7) can then be removed.



### CAUTION

Ensure the Electrode Stack (8) and PID Lamp (7) falls onto a soft surface such as a piece of tissue. This will avoid damaging the parts as they fall out and avoids finger contact with the PID Lamp window.

5. Clean the PID Lamp using the PID lamp cleaning kit (A-31063) **To clean the PID Lamp:**

- Open the vial of Aluminum Oxide polishing compound. With a clean cotton bud collect a small amount of compound.
- Use this cotton bud to polish the PID Lamp window. Use a circular action applying light pressure to clean the lamp window. Never touch the lamp window with fingers.
- Continue polishing until an audible "squeaking" is made by the cotton bud with compound moving over the window surface (usually within fifteen seconds).



Remove the residual powder with short blast of air from the can of air duster.



### INFORMATION

Contamination of the PID Lamp window can considerably reduce the detection capability of the MiniPID (4), even when the contamination is not visible. Cleaning of the lamp should be carried out on a regular basis depending on the PID Lamp (7) and the environment.

The humidity of the air and contaminants may affect the time required between servicing.

6. The Electrode Stack (8) should be inspected for visible signs of contamination, if contamination can be seen the Electrode Stack (8) must be replaced.

For more information on how to service your MiniPID sensor, watch our [tutorial video](#).

## Reassembly

1. Lay the Electrode Stack (8) front face down on a clean, flat surface and then screw the lamp (7) down into the O-ring until it firmly abuts against the front electrode face.
2. Place the MiniPID (4) body carefully down over the lamp-stack sub-assembly so as not to disturb its seating within the electrode stack and then push the body firmly onto the face down Electrode Stack (8) so that both wings engage with the MiniPID (4) body.
3. Inspect the sensor to confirm that both wings of the electrode stack have engaged with the MiniPID (4) body.
4. Refit the sensor into the sensing instrumentation.
5. The Falco must be calibrated.



### CAUTION

Irreparable damage will be caused by forcing the MiniPID (4) into the Sensor Housing if not correctly aligned.



### INFORMATION

Always calibrate the FALCO after servicing is carried out.

## Use of PID Lamp Cleaning Kit A-31063

The container of cleaning compound contains Aluminum Oxide as a very fine powder (CAS Number 1344-28-1).

The Compound has a TVL (TWA) of 10 mg/m<sup>3</sup> and a full material safety data sheet MSDS is available on request from Ion Science Ltd. The key issues are listed below:

### Hazard identification

May irritate the respiratory tract and eyes.

### Handling

- Do not breathe the vapour/dust.
- Avoid contact with skin, eyes, and clothing.
- Wear suitable protective clothing.
- Follow industrial hygiene practices;  
Wash face and hands thoroughly with soap and water after use and before eating, drinking, smoking, or applying cosmetics.
- Always replace the lid after using the cleaning compound.

### Storage

Keep the container closed to prevent water adsorption and contamination.

## Fault Diagnostics

### Alarm and Fault Indications



Activated when Alarm 1 is exceeded.



Activated when Alarm 2 is exceeded.



Activated when a fault condition is raised.

### Fault Conditions

The FALCO is equipped with diagnostics to ensure instrument faults are detected and communicated. The table gives a fuller description of each fault and lists some possible causes and corrective actions you can try. If the fault continues or is repeated, contact your Service Centre.

Displayed Fault Screen	Fault Description	Corrective Action
	If the user has exited the initial 30-minute warm-up phase, this screen will be displayed for 7 seconds until the lamp has struck.	Wait until the lamp has struck and the instrument displays a reading. If the lamp does not strike, replace it.
	The present gas concentration has 'over-ranged' the instrument. The instrument can't display readings greater than 19999 (3000ppm) or 1999.9 (1000ppm) or 199.99 (50ppm) or 19.999 (10ppm).	Wait until gas concentration returns to lower levels and the instrument reading reappears.
	The lamp is not lit during a measurement cycle, or the PID is not installed.	Replace the Lamp or insert the PID
	The analogue-to-digital converter has stopped working.	Contact the Service Centre.
	If error 3 occurs, the Falco's lamp hasn't struck.	Make sure the Sensor Cover is screwed on correctly. Replace the lamp if the error persists.
	Low System Flow Rate	Check the sample line for blockages. Also, check the hydrophobic filter for a large ingress of water. If the filter has water in it, eliminate the source of the water (where possible) and replace the filter.
	The analogue-to-digital converter has stopped working.	Check that the ribbon cable is correctly fitted between the main and display PCBA/s.
	Flow System Blocked	Check the sample line for blockages. Also, check the hydrophobic filter for a large ingress of water. If the filter has water in it, eliminate the source of the water (where possible) and replace the filter.

## Manual Log

Manual Version	Amendment	Issue Date	Instrument (main unit) Firmware	Instrument (Sensor module) Firmware	PC Software
1.0	First Issue	23/10/2024	0.0.34	0.1.14	n/a
1.1	<p>North America QPS certification added to user manual.</p> <p>Correction to storage temperature update</p> <p>Falco &amp; Falco TAC – MiniPID Spares updated</p> <p>Box packing list added</p> <p>4- 20 mA calibration setup and fault mA signal added</p> <p>General formatting tidy-up and improved wording in sections</p>	22/07/2025	0.0.38	0.1.14	n/a
1.2	<p>Minor improvements and corrected North American certification marking to include missing 'Gb' classification in explosion protection labelling.</p> <p>Added section on regular bump testing.</p> <p>Updated Modbus table with additional addresses to support enhanced remote monitoring, including setting and reading alarm levels.</p> <p>Formatting and text improvement.</p>	31/10/2025	0.0.38	0.1.14	n/a

**Disclaimer:** Information in this manual is subject to change without notice and does not represent a commitment to the part of Ion Science. No claims, promises or guarantees are made about the accuracy, completeness, or adequacy of the information contained herein.

## Quality Assurance

The FALCO 2 instruments are manufactured by ION Science Limited within an ISO 9001 compliant quality management system, which ensures that the equipment supplied to our customers has been designed and assembled reproducibly, and from traceable components.

## Warranty

Register your instrument online for an extended warranty

Thank you for purchasing your ION Science instrument.

The standard warranty of your FALCO 2 VOC Monitor is for one year.

To receive your extended warranty, you must register your instrument online within one month of purchase (terms and conditions apply.)

## ION Science Contact Details

### ION Science Ltd – UK/Head Office

Tel: +44 (0)1763 208 503

Web: [www.ionscience.com](http://www.ionscience.com) | Email: [info@ionscience.com](mailto:info@ionscience.com)

### ION Science Inc – USA Office

Tel: +1 877 864 7710

Web: <https://ionscience.com/usa/> | Email: [info@ionscienceusa.com](mailto:info@ionscienceusa.com)

### ISM ION Science Messtechnik – Germany Office

Tel: +49 (0) 2104 1448-0

Web: <https://www.ism-d.de/en/> | Email: [sales@ism-d.de](mailto:sales@ism-d.de)

### ION Science France – France Office

Tel: +33 613 505 535

Web: [www.ionscience.com/fr](http://www.ionscience.com/fr) | Email: [info@ionscience.it](mailto:info@ionscience.it)

### ION Science Italy - Italy Office

Tel: +39 051 0561850

Web: [www.ionscience.com/it](http://www.ionscience.com/it) | Email: [info@ionscience.com](mailto:info@ionscience.com)

### ION Science India - India Office

Tel: +914048536129

Web: [www.ionscience.com/in](http://www.ionscience.com/in) | Email: [kschhari@ionscience.com](mailto:kschhari@ionscience.com)

### ION Science China - China Office

Tel: +86 21 52545988

Web: [www.ionscience.com/cn](http://www.ionscience.com/cn) | Email: [info@ionscience.cn](mailto:info@ionscience.cn)