



XP CLIMATE CONTROL LLC  
3299 Bamboo Rd. Boone NC 28607  
PO Box 432 Blowing Rock N.C. 28605  
828-266-2006/866-292-7506  
info@xpclimate.com  
www.xpclimate.com

EP-MS12HP-2-2-X-(IE)-216-1Z  
Explosion Proof Single Zone Mini Split System Heat Pump  
Interior/Exterior: Class 2 Division 1 Groups E,F,G  
208-230 Volt, 1 Phase, 60 hertz ~ 12,000 BTU/H

## SUBMITTAL DATA



## GENERAL FEATURES

- High Efficiency DC Inverter Technology
- Compact and Quiet Design
- Wireless Remote with LCD Display
- Composite Drain Pan
- Owners & Maintenance Manuals Included
- Explosion Proof Motor and Overload Protection Installed
- Certificate of Conformance to NEC Codes Issued
- Low Ambient Cooling and Heating
- Coil (Indoor and Outdoor) Copper Tube / Aluminum Fin
- Blue Colored Fin - 500 Hrs Salt Spray Tested
- Wall-Mounted Evaporator Section
- Refrigerant Type: R32



**SPECIALIZED EXPLOSION PROOF SYSTEMS**

SYSTEM TYPE		HEAT PUMP		FEATURES & FUNCTIONS SUMMARY	
Outdoor Model				Inverter Type	G20
Indoor Model				Ultra Low Frequency Torque Control	Yes
SYSTEM PERFORMANCE					
Cooling Capacity	Min - Max	Btu/h	3,070 - 13,300		
	Rated Capacity @95°F	Btu/h	12,000		
Heating Capacity	Min - Max	Btu/h	3,070 - 14,600		
	Rated Capacity @47°F	Btu/h	12,000		
	Rated Capacity @17°F	Btu/h	9,700		
	Rated Capacity @5°F	Btu/h	9,100		
SEER2		19.0			
EER2		9.75			
HSPF2		8.5			
COP @5°F		1.75			
Cooling Temperature Range		°F	0 - 118		
Heating Temperature Range		°F	-13 - 75		
Refrigerant Type		R32			
INDOOR UNIT					
Air flow (Min - Max)		CFM	182 - 424		
Sound Pressure Level (Min - Max)		dB(A)	27 - 47		
Dehumidification		pT/hr	2.96		
External Dimensions (W x H x D)		in	40 × 10-53/64 × 7-7/8		
Net Weight		lbs	31.8		
Gross Weight		lbs	36.3		
OUTDOOR UNIT					
Compressor Type		GREE G20 / SINGLE CYLINDER / 1 - STAGE INVERTER			
Sound Pressure Level		dB(A)	52		
External Dimensions (W x H x D)		in	28-13/16 x 31 x 16-27/32		
Net Weight		lbs	134.2		
Gross Weight		lbs	139.7		
REFRIGERANT PIPING					
Refrigerant Charge - R32		oz	17.6		
Additional Charge		oz/ft	0.2		
Line Set Size (Liquid - Gas) - Flared Connections		in	1/4 - 3/8		
Pre-Charge Length		ft	25		
Pipe Length (Min - Max)		ft	10 - 66		
Max. Pipe Elevation		ft	40		
ELECTRICAL					
Power Supply		208-230V / 1PH / 60Hz Powered by the Outdoor Unit)			
Voltage Range (Min - Max)		VAC	187 - 253		
Rated Current - Cooling		A	7.02		
Rated Current - Heating		A	7.47		
MOCP		A	15		
MCA		A	12		
Main Power Wire Size		AWG	Per Local Code		
Interconnecting Wire Size		AWG	14 / 4		
REMOTE CONTROLLER FUNCTIONS					
Auto Mode		Yes			
Auto Fan		Yes			
Manual Horizontal Swing		Yes			
Auto Swing (Vertical Auto Swing)		Yes			
Clock on Remote Controller		Yes			
Dry Mode		Yes			
Dry Anti-Mildew (X-Fan) Mode		Yes			
Energy Saving Mode		Yes			
Dirty Filter Alert		No			
I Feel Function		Yes			
Lock on Remote Controller		Yes			
Quiet Mode		Yes			
Room Temperature Display		Yes			
Sleep Mode		Yes			
Timer Mode		Yes			
Turbo Mode		Yes			
Display On/Off Control		Yes			
Freeze Guard Mode (46°F)		Yes			
Display On/Off Control		Yes			

INDOOR UNIT

Unit: inch

DIMENSIONS	
W	40
H	10 53/64
D	7 7/8
W1	7 1/64
W2	18 3/16
W3	7 43/64

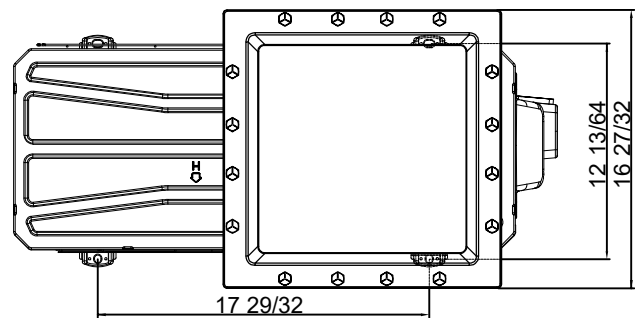
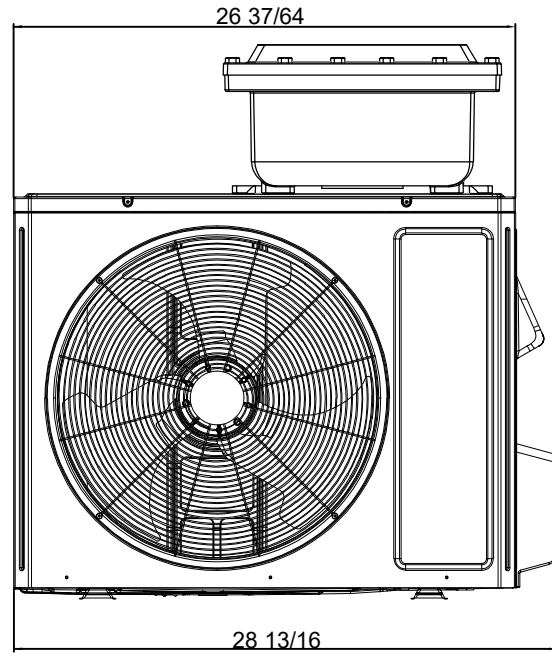
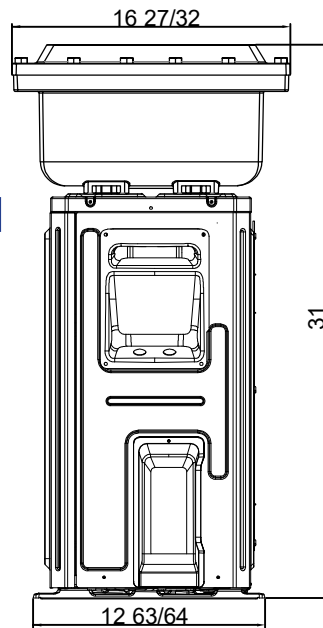
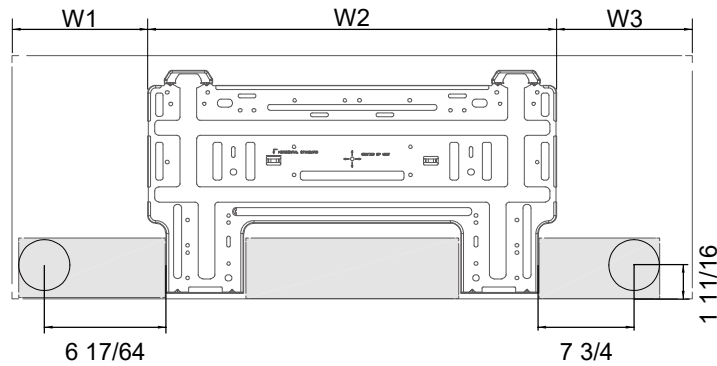
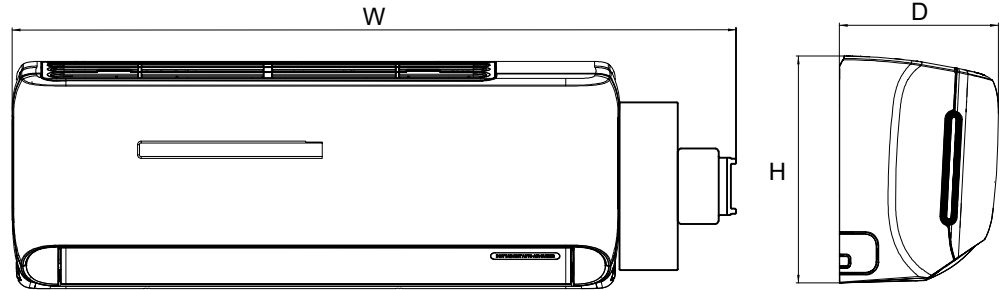

OUTDOOR UNIT

Unit: inch

