

ZONE 1

EFi50xx/EFi120xx/EFi150xx

16"/40 cm

Blower/Exhauster

The electric powered EFixx Series hazardous location blowers/exhausters, with **whole-unit certification**, are intended for use in Adverse Atmospheres in accordance with the limitations of the rating. The whole-unit certification not only provides protection and peace of mind to the user; it also prevents suppliers from being linked to the chain of liability.

The largest hazardous location blowers for highest volume of air movement. Use the EFi50xx (0.5 Hp) when you need a high volume, low velocity, somewhat gentler flow; or the EFi150xx (1.5 Hp) model for higher velocities, increased volumes and reduced purge or cooling times. 16" (40 cm) integrated duct adapters. Stackable in storage or during operation.

Specifications

Model	EFi50xx (115V/230V)		EFi120xx (110V/240V)		EFi150xx (115V/230V)	
Part #	EA8000XX Ships as 115V	EA8000XX-230 Ships as 230V	EA8120XX-110 Ships as 110V	EA8120XX Ships as 240V	EG8200XX Ships as 115V	EG8200XX-230 Ships as 230V
IMPA Code					591507	
Motor	0.5 Hp / 0.37 kW		1.2 Hp / 0.9 kW		1.5 Hp / 1.1 kW	
Motor Type	Totally Encapsulated Air Flame Proof					
Electric	115/230V, 1ø, 50/60Hz		110/240V, 1ø, 50Hz		115/230V, 1ø, 50/60 Hz	
Amps (Start/Run)	25A / 6A	13A / 3A	54A / 10A	27A / 5A	80A / 15A	40A / 8A
Cable Lengths	30'/9m, 14AWG/2.5mm ²		25'/7.6m, 14AWG/2.5mm ²			
Plug Types	Not Included		A.T.X. 100/130V	A.T.X. 240V	A.T.X. 100/130V	A.T.X. 240V
Operating Temperature	-22°F to +104°F / -30°C, to +40°C					
Noise	90.2 dB @ 3' (1 m)		86.1 dB @ 3' (1 m)		90.2 dB @ 3' (1 m)	
Weight	49 lbs / 22 kg		55 lbs / 25 kg		61 lbs / 28 kg	
Dimensions (h/w/d)	19 x 18 x 16 in / 48 x 46 x 41 cm					
Impeller	21-Blade		7-Blade			

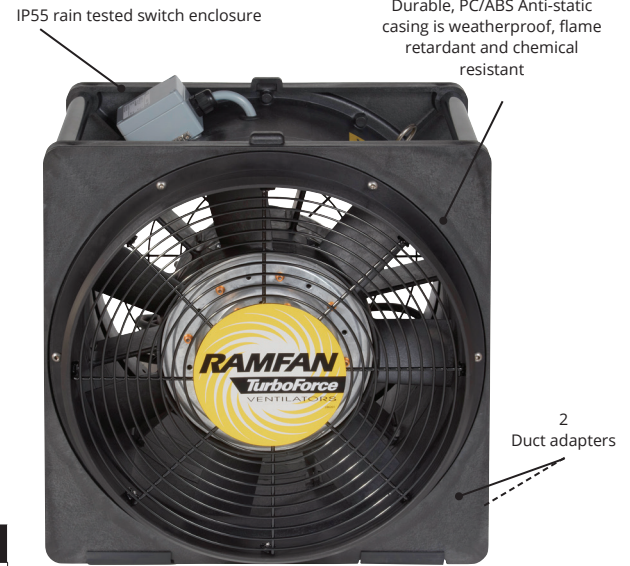

* EFi50xx has 21 blades

«Certifications & Approvals

Certification String: II 2 G EX de IIB T6 Gb

IECEx UL Certificate #: **13.0062X**

EC-Type Examination Certificate #: **DEMKO 09 ATEX 0926969X**

CE Hazardous Location Marking: **CE0539**

Ingress Protection: **IP55**

EFi150xx Approval

INMETRO Certificate #: **UL-BR 13.0593X**

EFi50xx Motor Approval LISTED Class I-II Group D,

EFi50xx Motor Part Number 1131007404



Performance

Airflow	EFi50xx	EFi120xx	EFi150xx
Free Air	3,200 cfm (5,440 m ³ /hr)	3,750 cfm (6,375 m ³ /hr)	4,459 cfm (7,580 m ³ /hr)
Through Duct 15'/4.6 m w/ one 90° turn:	1,935 cfm (3,289 m ³ /hr)	2,700 cfm (4,590 m ³ /hr)	3,179 cfm (5,404 m ³ /hr)

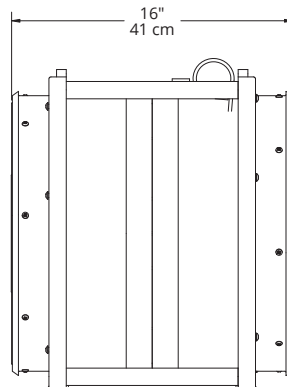
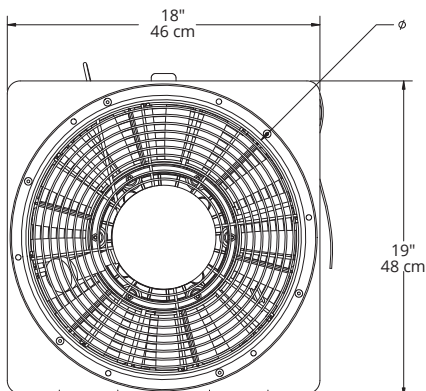

Available Accessory

ECKO Flex™ Anti-Static Duct with carrying bag

Order # FDT-1615CBR

16" (40cm) anti-static duct
15' (4.6 m), w/ carrying bag



Order # FDT-1625CBR

16" (40cm) anti-static duct
25' (7.6 m), w/ carrying bag

Silent Guard

Order # EA7108

Reduction of noise: 7db
decrease in 3ft (1m) and 10
Ft (3m) setback

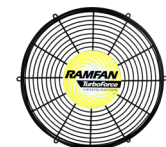

This accessory cannot be
used with duct adapter on
section side.