



Via Enrico Fermi, 2
I-25015 Desenzano del Garda (BS) - Italy
Phone: +39 030 7870787
Fax: +39 030 7870777
www.solexy.net

BAF

Intrinsically Safe Ethernet Coupler for signals operating in
Hazardous Areas

Installation & Operation Manual

OVERVIEW

The Solexy BAF intrinsically safe Ethernet couplers are an integrated protection device that facilitates Ethernet cabling installation in hazardous areas making the signal intrinsically safe. The patented (7,507,105) BAF coupler features a barrier circuit which protects the field cabling from faults or voltage and current high enough to cause a spark ignition. The BAF circuit is encapsulated and housed in an aluminum or stainless steel housing and is designed to operate as an intrinsically safe barrier located in a safe area. The BAF intrinsically safe Ethernet coupler can be used with most PC's, Switches, Gateways and other Ethernet devices to ensure intrinsic safety for communicating into a hazardous area.

Note: The information in this manual is intended to assist with equipment design and ensure proper installation for all device with serial number starting from 12865.

READ THIS INSTRUCTION FIRST

To avoid serious or fatal personal injury or major property damage, read and follow all the safety instruction in this manual. If you require additional assistance, please contact SOLEXY.

SAFETY INSTRUCTION TO HAZARDOUS AREA INSTALLATION

- The Solexy BAF intrinsically safe Ethernet coupler must be installed and maintenance according to suitable standards for electrical application in potentially explosive atmospheres (IEC/EN 60079-14, IEC/EN60079-17 and/or other national standards).
- Suitably trained personnel shall carry out installation according with applicable code practice.
- Read this first and keep this instruction manual always available.
- For proper installation, see the applicable control drawing DD CD-0001 attached.
- Ethernet wiring allowed up to -25°C

ATEX / IECEx MARKING



I (M1)	[Ex ia Ma] I
II (1) G	[Ex ia Ga] IIC
II (1) D	[Ex ia Da] IIIC

This instruction refers to certified equipment covered by following certificate:

ATEX: TÜV CY 18 ATEX 0206141 X
IECEx: IECEx MSC 18.0014X

WARNINGS

1. The Solexy BAF is an associated apparatus and shall only be installed in a non-hazardous location.
2. This device will not work with POE, using it with POE could result in equipment damage.
3. This device is intended for 10/100 Mbps Ethernet.
4. Length of cable that it is permitted at the output of the unit is dependent on the Lo and Co values assigned, see EN/IEC 60079-14, clause 16.2.2.2
5. The Solexy Ethernet Barrier field connections MUST be used with M12, 4-pin "D" coded connectors. Any other type of M12 connector will not work or fit into the barrier. See drawing DD CD-0003.
6. The user should not repair this equipment.
7. The user should not modify the unit.
8. The unit should not painted by the user.
9. If the equipment is likely to come in contact with aggressive substances, is responsibility of the user to take suitable precautions that prevent it from being adversely affected, thus ensuring that the type of protection is not compromised. Aggressive substances like acids, liquids, gases that can affect metals.

INSTALLATION

1. For proper installation, see the applicable control drawing DDCD-0001 attached.
2. Mount BAF with bracket or just leave hanging in-line in safe area location.
3. Make sure that proper grounding occurs per IEC/EN 60079-14 standard and local electrical code.
4. If part of the equipment is in a safe area then the circuit can be completed with the BAF series coupler, make sure that proper grounding occurs per local codes.
5. Because the limitation circuitry is referenced to earth/case, it does not meet the dielectric strength requirement specified in Clause 6.3.13 of EN 60079-11. This must be considered during installation.
6. Attach Ethernet connection to bus system at each end via BXF/BAF pigtail connector according to control drawing listed above.
7. For proper wiring and cable make up, if not using a factory supplied cable, refer to control drawing DDCD-0003.
8. Attach interconnecting cable between barriers per control drawing listed above.

PRODUCT SPECIFICATIONS

Ambient Temperature Range	-40°C to +85°C
Maximum Fault Voltage	250 VAC - 48 VDC
Maximum Ethernet Power Output	1 Watts
Maximum Current	50 mA
Data Rate	10/100 Mbps
DC Resistance (per conductor)	41 Ω

Um	250 VAC at 50-60 Hz, 48 VDC 2.8V at 100 MHz
Uo	3.328V at 50-60 Hz 2.8V at 100 MHz
Io	701 mA at 50-60 Hz 1.17 A at 100 MHz
Co	1000 μF
Lo	37 μH

GROUNDING

1. Grounding need to make according to IEC/EN 60079-14 and/or other national standards
2. Earth grounding is required at both ends of the circuit
3. All Grounds need to be at the same voltage potential, if one of the point of installation has a different electrical potential it's necessary to ensure equipotential bonding in accordance with IEC/EN 60079-14
4. Cable must be shielded and grounded according to IEC/EN 60079-14

PRODUCT'S STORAGE

Keep the boxes away from atmospheric agents in an environment with temperature between 0°C and 40°C.

MAINTENANCE

- The verification and maintenance of the electrical equipment must be performed according to IEC/EN 60079-17.
- The user should guarantee the keeping of the safety characteristic of the device after maintenance.
- The maintenance related the components used for wiring must be performed according to manufacturer instruction.

DISPOSAL / RECYCLING

Disposal and recycling of the product according to national regulation for waste disposal and recycling.

WARNING: Do not dispose the product and the components in the environment.

INSTALLATION REQUIREMENTS:

- In addition to the attached pigtail lead, the BAF must additionally be grounded via either the threaded connection or the supplied grounding screw. Secondary pigtail is supplied for connection to grounding screw.
- The Ethernet terminal or hub supply shall be a maximum of 250VAC or 48VDC with a standard Ethernet output. Supply voltage must be from same phase source at both ends.
- Secure BAF with supplied panel nut or with bracket.
- Since U_m is less than 250 V, $U_m = 2.8V$ at 100 MHz, the apparatus shall be installed in accordance with one of the following options to ensure an input voltage of 2.8V is not exceeded according to EN/IEC 60079-14 clause 16.2.1 :
 - Where U_m does not exceed 50 V a.c., or 120 V d.c., in a SELV PELV system, or
 - Via a safety isolating transformer complying with the requirements of IEC 61558-2-6, or technically equivalent standard.
 - Directly connected to apparatus complying with the IEC 60950 series, IEC 61010-1, or a technically equivalent standard, or
 - Fed directly from cells or batteries
- Only to be used with another BXF or BAF Ethernet coupler.
- Ambient operating temperature (T_a): -40°C to +85°C
- Ethernet wiring allowed up to -25°C
- Terminal refers to any endpoint device such as a computer. Hub refers to any branching device such as a switch, router, etc.
- ANY CHANGE(S) IN THE INTRINSICALLY SAFE CIRCUITRY OR COMPONENTS MAY RESULT IN AN UNSAFE CONDITION.
- Refer to drawing DCCD-0002 for BXF connections.
- The BAF must be installed in a non-hazardous location.
- Consideration must be given during installation that the BAF limitation circuitry is referenced to earth/case. As a result it does not meet the dielectric strength requirement specified in Clause 6.3.13 of EN/IEC 60079-11.
- Length of cable that is permitted at the output of the BAF unit is dependent on the Lo and Co values assigned to the device, see EN/IEC 60079-14, clause 16.2.2.2

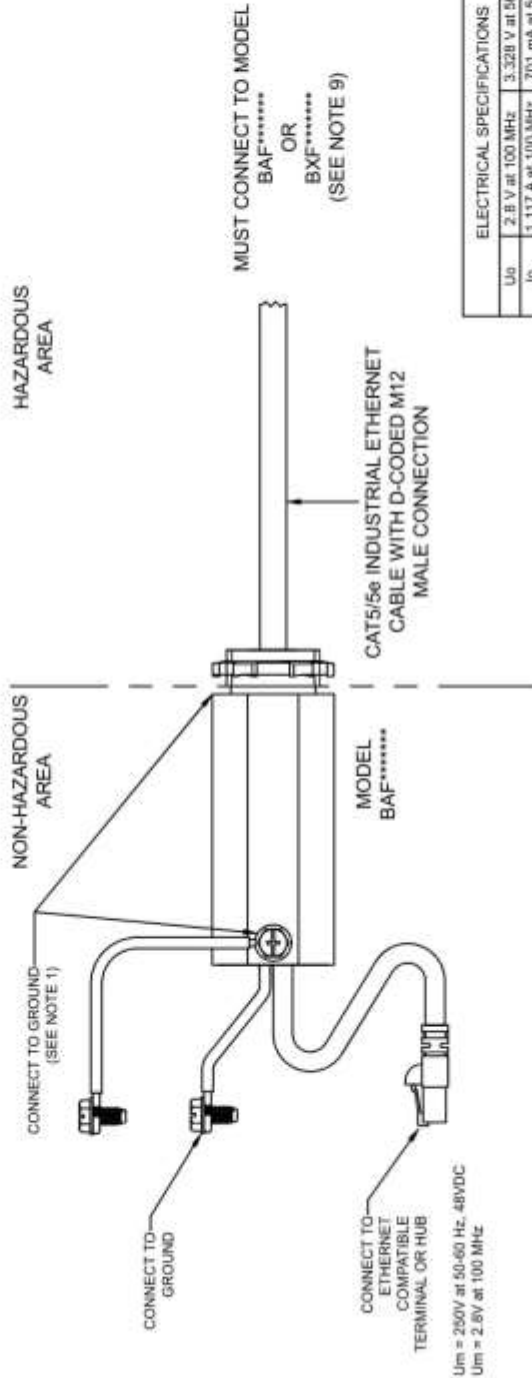

U0	2.8 V at 100 MHz	3.328 V at 50-60 Hz
I0	1.117 A at 100 MHz	701 mA at 50-60 Hz
Co		1000 µF
Lo		37 µH

SCHEDULE DRAWING
No modifications permitted
without reference to the
Notified Body

CONNECTIONS	CABLE TYPE
TERMINAL to HUB	STANDARD
TERMINAL to TERMINAL	CROSSOVER
HUB to HUB	CROSSOVER

UNITS mm	SCALE N/A	MATERIAL N/A	FINISH N/A	DRAWN BY SS	DATE 11/07/2018	TITLE CONTROL DRAWING BAF ATEX/IECEx	SHEET NO. 1 OF 1
UNLESS OTHERWISE SPECIFIED GENERAL TOLERANCES	ANGLE OF PROJECTION N/A			CHECK BY GS	DATE 11/07/2018		
X .XX XXX	mm +0.10 +0.20			APPROV BY GS	DATE 15/07/2018	SIZE A	DRAWING NUMBER DCCD-0001-S
CONCENTRICITY ANGLES	+0.05 +0.13					REV	REV
				SS	SS	GS	GS
				DRAWN	CHECK	APPRD	BY
				BY	BY	BY	BY
REV	DATE	ECN	DESCRIPTION				
01	31-05-2018	-	Update electrical specifications and note 4				



This design and all dimensions contained in this drawing were approved by, and in the exclusive property of, Solexy. It is intended for information only and is not to be used for manufacturing or reproduction in any form without the express written permission of Solexy.

OVERVIEW

The Solexy BXF explosion proof and intrinsically safe Ethernet coupler is an integrated protection device that facilitates Ethernet cabling installation in hazardous areas making the signal intrinsically safe. The patented (7,507,105) BXF coupler features a barrier circuit which protects the field cabling from faults or voltage and current high enough to cause a spark ignition. The BXF circuit is encapsulated and housed in an explosion-proof stainless steel body and is designed to be used with an ATEX Listed enclosure for hazardous areas.

By utilizing the couplers with a certified enclosure, your system will be approved for hazardous area use with most PC's, Ethernet Switches, Hubs and Masters.

Note: The information in this manual is intended to assist with equipment design and ensure proper installation for all device with serial number starting from 12865.

READ THIS INSTRUCTION FIRST

To avoid serious or fatal personal injury or major property damage, read and follow all the safety instruction in this manual. If you require additional assistance, please contact SOLEXY.

SAFETY INSTRUCTION TO HAZARDOUS AREA INSTALLATION

- The Solexy BXF explosion proof and intrinsically safe Ethernet coupler must be installed and maintenance according to suitable standards for electrical application in potentially explosive atmospheres (IEC/EN 60079-14, IEC/EN60079-17 and/or other national standards).
- Suitably trained personnel shall carry out installation according with applicable code practice.
- Read this first and keep this instruction manual always available.
- For proper installation, see the applicable control drawing DDCCD-0002 attached.
- Ethernet wiring allowed up to -25°C

ATEX / IECEx MARKING



I M2 (M1) Ex db mb [ia Ma] I Mb
II 2 (1) G Ex db mb [ia Ga] IIC T5...T4 Gb
II 2 (1) D Ex mb [ia Da] IIIC T100°C...T135°C Db

NOTE = Refer to product marking if T4 and T135C class is allowed

This instruction refers to certified equipment covered by following certificate:

ATEX: TÜV CY 18 ATEX 0206141 X
IECEX: IECEX MSC 18.0014X

WARNINGS

1. The free end of the cemented bushing and its associated integral cable shall be protected by a suitable enclosure utilizing one of the protection types listed in Clause 1 of EN 60079-0. The protection type utilized shall be applicable to the specific area of use (i.e. Gas or Dust).
2. For EPL Ma only: in accordance with Clause 26.4.2 of EN 60079-0, the BXF3s and BXFMS have been tested corresponding to a low risk of mechanical danger for Group I hazardous locations. This must be considered during installation.
3. This device will not work with POE, using it with POE could result in equipment damage.
4. This device is intended for 10/100 Mbps Ethernet.
5. Length of cable that it is permitted at the output of the unit is dependent on the Lo and Co values assigned, see EN/IEC 60079-14, clause 16.2.2.2
6. The Solexy Ethernet Barrier field connections MUST be used with M12, 4-pin "D" coded connectors. Any other type of M12 connector will not work or fit into the barrier. See control drawing DDCCD-0003.
7. The user should not repair this equipment.
8. The user should not modify the unit.
9. The unit should not painted by the user.
10. If the equipment is likely to come in contact with aggressive substances, is responsibility of the user to take suitable precautions that prevent it from being adversely affected, thus ensuring that the type of protection is not compromised. Aggressive substances like acids, liquids, gases that can affect metals.

INSTALLATION

1. For proper installation, see the applicable control drawing DDCCD-0002 attached.
2. Feed the Ethernet cable through the enclosure conduit entry. In order to avoid any cable's damage do not attach the Ethernet cable to the device until the BXF is completely screwed.
3. Screw coupler into enclosure following IEC/EN 60079-14 standard and local electrical code
4. If part of the equipment is in a safe area then the circuit can be completed with the BAF series coupler, make sure that proper grounding occurs per local codes.
5. Because the limitation circuitry is referenced to earth/case, it does not meet the dielectric strength requirement specified in Clause 6.3.13 of EN 60079-11. This must be considered during installation.
6. Attach Ethernet connection to bus system at each end via BXF/BAF pigtail connector according to control drawing listed above.
7. For proper wiring and cable make up, if not using a factory supplied cable, refer to control drawing DDCCD-0003.
8. Attach interconnecting cable between barriers per control drawing listed above.

PRODUCT SPECIFICATIONS

Ambient Temperature Range	T5 = -40°C to +65°C T4 = -40°C to +85°C ¹
Maximum Fault Voltage	250 VAC - 48 VDC
Maximum Ethernet Power Output	1 Watts
Maximum Current	50 mA
Data Rate	10/100 Mbps
DC Resistance (per conductor)	41 Ω

¹ Refer to product marking if allowed

Um	250 VAC at 50-60 Hz, 48 VDC 2.8V at 100 MHz
Uo	3.328V at 50-60 Hz 2.8V at 100 MHz
Io	701 mA at 50-60 Hz 1.17 A at 100 MHz
Co	1000 μF
Lo	37 μH

GROUNDING

1. Grounding need to make according to IEC/EN 60079-14 and/or other national standards
2. Earth grounding is required at both ends of the circuit
3. All Grounds need to be at the same voltage potential, if one of the point of installation has a different electrical potential it's necessary to ensure equipotential bonding in accordance with IEC/EN 60079-14
4. Cable must be shielded and grounded according to IEC/EN 60079-14

PRODUCT'S STORAGE

Keep the boxes away from atmospheric agents in an environment with temperature between 0°C and 40°C.

MAINTENANCE

- The verification and maintenance of the electrical equipment must be performed according to IEC/EN 60079-17.
- The user should guarantee the keeping of the safety characteristic of the device after maintenance.
- The maintenance related the components used for wiring must be performed according to manufacturer instruction.

DISPOSAL / RECYCLING

Disposal and recycling of the product according to national regulation for waste disposal and recycling.

WARNING: Do not dispose the product and the components in the environment.

INSTALLATION REQUIREMENTS:

- The BXF must be securely mounted and grounded within an ATEX/IECEx approved explosion-proof enclosure. Both the housing and attached pigtail lead must be grounded.
- The Ethernet terminal or hub supply shall be a maximum of 250Va.c. or 48Vd.c. with a standard Ethernet output. Supply voltage must be from same phase source at both ends.
- The BXF thread engagement with the approved explosion-proof enclosure shall be 1/2 inch (12.7 mm) penetration with minimum 5 thread engagement.
- Since U_m is less than 250 V, $U_m = 2.8V$ at 100 MHz, the apparatus shall be installed in accordance with one of the following options to ensure an input voltage of 2.8V is not exceeded according to EN/IEC 60079-14 clause 16.2.1 :
 - Where U_m does not exceed 50 Va.c., or 120 Vd.c., in a SELV PELV system, or
 - Via a safety isolating transformer complying with the requirements of IEC 61558-2-6, or technically equivalent standard,
 - Directly connected to apparatus complying with the IEC 60950 series, IEC 61010-1, or a technically equivalent standard, or
 - Fed directly from cells or batteries

- Only to be used with another BXF or BAF Ethernet coupler.
- Ambient operating temperature (T_a):
 - $T_5 = -40^{\circ}C$ to $+65^{\circ}C$
 - $T_4 = -40^{\circ}C$ to $+85^{\circ}C$ (refer to product marking if allowed)
 Ethernet wiring allowed up to $-25^{\circ}C$
- Terminal refers to any endpoint device such as a computer. Hub refers to any branching device such as a switch, router, etc.
- ANY CHANGE(S) IN THE INTRINSICALLY SAFE CIRCUITRY OR COMPONENTS MAY RESULT IN AN UNSAFE CONDITION.**
- Refer to drawing DDCD-0001 for BAF connections.
- Consideration must be given during installation that the BXF limitation circuitry is referenced to earth/case. As a result it does not meet the dielectric strength requirement specified in Clause 6.3.13 of EN/IEC 60079-11.
- In case of use of a Ex tb enclosure with metric entries ensure 5 engaged threads minimum or use an appropriate gasket.
- In case of use of a Ex tb enclosure with NPT entries ensure 3 engaged threads minimum.
- It is responsibility to the installer to ensure an IP6x level at the threaded joint between Ethernet coupler and Ex tb enclosure.
- Length of cable that is permitted at the output of the BXF unit is dependent on the Lo and Co values assigned to the device, see EN/IEC 60079-14, clause 16.2.2.2

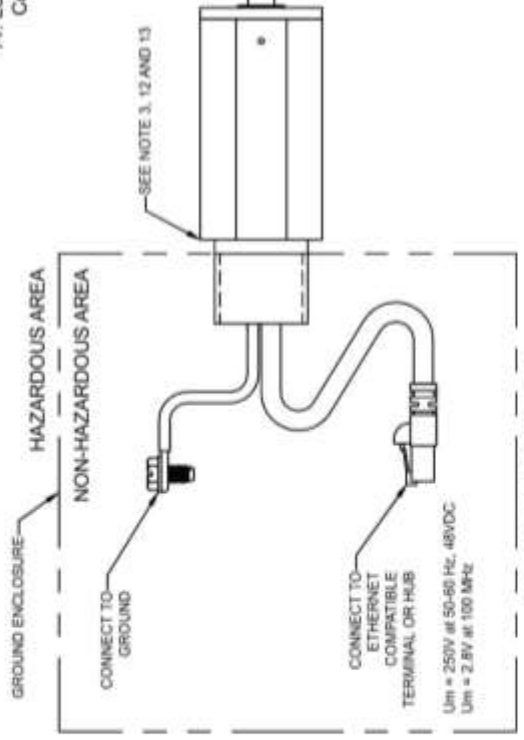

APPROVED HOUSING FOR HAZARDOUS AREA

ELECTRICAL SPECIFICATIONS	
Us	2.8 V at 100 MHz 3.328 V at 50-60 Hz
Ic	1.177 A at 100 MHz 7.071 mA at 50-60 Hz
Co	1000 µF
Lo	37 µH

SCHEDULE DRAWING
No modifications permitted
without reference to the
Notified Body

MODEL	THREAD CONNECTION
BXF3	3/4-14 NPT
BXFM	M25 x 1.5

CABLE CONFIGURATION	
CONNECTIONS	CABLE TYPE
TERMINAL to HUB	STANDARD
TERMINAL to TERMINAL	CROSSOVER
HUB to HUB	CROSSOVER

REV	DATE	ECN	DESCRIPTION	SS	SS	SS	GS	APPRD	BY
01	31-05-2019	-	Update electrical specifications and note 4	DRAWN	CHECK	APPRD	BY		

		SHEET NO. 1 OF 1	
UNITS mm		MATERIAL N/A	
SCALE N/A		FINISH N/A	
ANGLE OF PROJECTION N/A		DRAWN BY SS	
UNLESS OTHERWISE SPECIFIED GENERAL TOLERANCES		DATE 11/07/2018	
X	ISO 278	SS	CHECK BY
XX	ISO 143	GS	DATE
XXX	ISO 113	GS	APPRD BY
CONCENTRICITY	ISO 113	GS	DATE
ANGLES	ISO 113	GS	DATE
TITLE CONTROL DRAWING BXF		ATEX/IECEx	
SIZE A		DRAWING NUMBER DDCD-0002-S	
REV 01		REV 01	

This drawing and associated information is the exclusive property of Solexy, S.A. Any reproduction, distribution, sale or use of this information in any form without the express written permission of Solexy is strictly prohibited. This drawing is not to be reproduced or copied in any form without the express written permission of Solexy.