

DT-5K-FSR-NI

DATE	CHANGES	INTL	REV
06.13.18	Original	AH	1.0
07.31.18	Added isolation barrier to wiring concept	AH	1.1
09.13.18	Removed isolation barrier, added Nonincendive Field Wiring to concept	AH	1.2
12.18.18	Updated to Pepperl Fuchs isolation barrier	AH	1.3
01.07.19	Added PG7 cable gland option	AH	1.3
05.13.19	Updated to PS2-IS-BARRIER	CW	2.0

DESCRIPTION: The DT-5K-FSR-NI combines a Force Sensing Resistor pointing device with a 10-key numeric keypad in a ruggedized stainless steel case carrying the FM Approvals Non-Incendive Certification.

USE: The DT-5K-FSR-NI is designed for use in Hazardous Locations as detailed below. The keyboard must be used in combination with the iKey PS2-IS-BARRIER.

MAINTENANCE: There are no serviceable parts on this assembly.

INSTALLATION: The DT-5K-FSR-NI and the PS2-IS-BARRIER should only be installed in Hazardous Locations as detailed in the Certification and Operating Specifications section. Installation shall be in accordance with NEC, Article 504, ANSI, NFPA 70, reference Drawing Number HL0067.

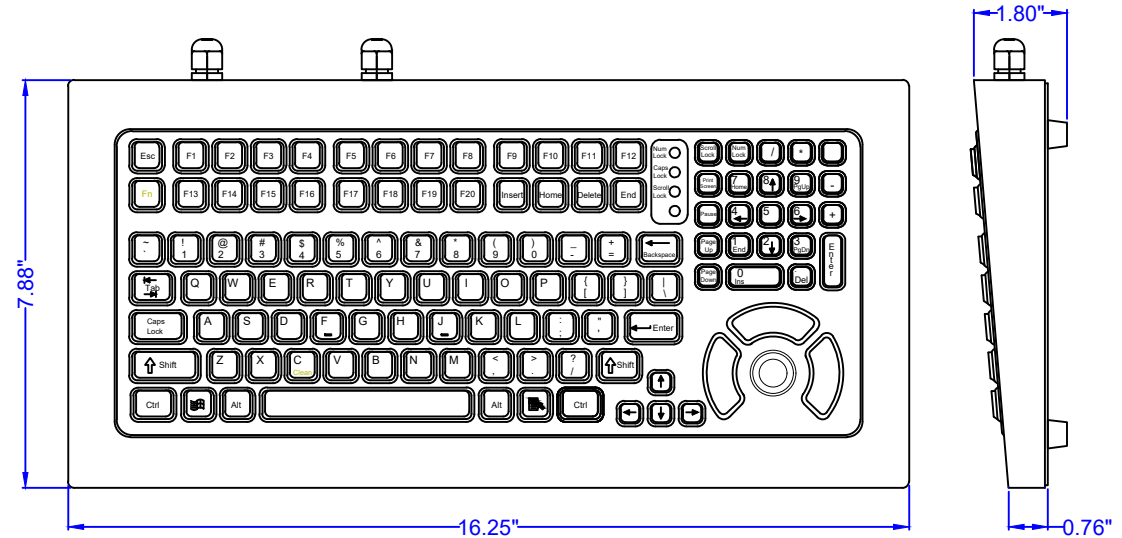

CERTIFICATION AND OPERATING SPECIFICATIONS:

NON-INCENDIVE:
Class I, Division 2, Groups A/B/C/D

STANDARDS FOR US APPROVAL:
FM3600:2018, FM3610:2018, FM3611:2018, FM3810:2018, ANSI/UL 60079-0:2013 (Group IIB), ANSI/ISA 12.12.0:2015, ANSI/ISA 61010-1:2012, NEMA250:2014

TEMPERATURE CLASS:
T4 (-40°C ≤ T4 ≤ +75°C)

POWER:
Reference Drawing Number HL0067 for Power Requirements

ENCLOSURE TYPE:
Type 4X

WEIGHT:
6.75 lbs +/- 0.10lbs (3.06 kg +/- 0.05kg)

No revision to drawing
w/o prior FM approval

PROPRIETARY AND CONFIDENTIAL

ASSEMBLING AND DISMANTLING: The DT-5K-FSR-NI keyboard must be assembled with the PS2-IS-BARRIER as shown in the connection diagram below and in accordance with Drawing Number HL0067. There are no serviceable parts in this assembly.

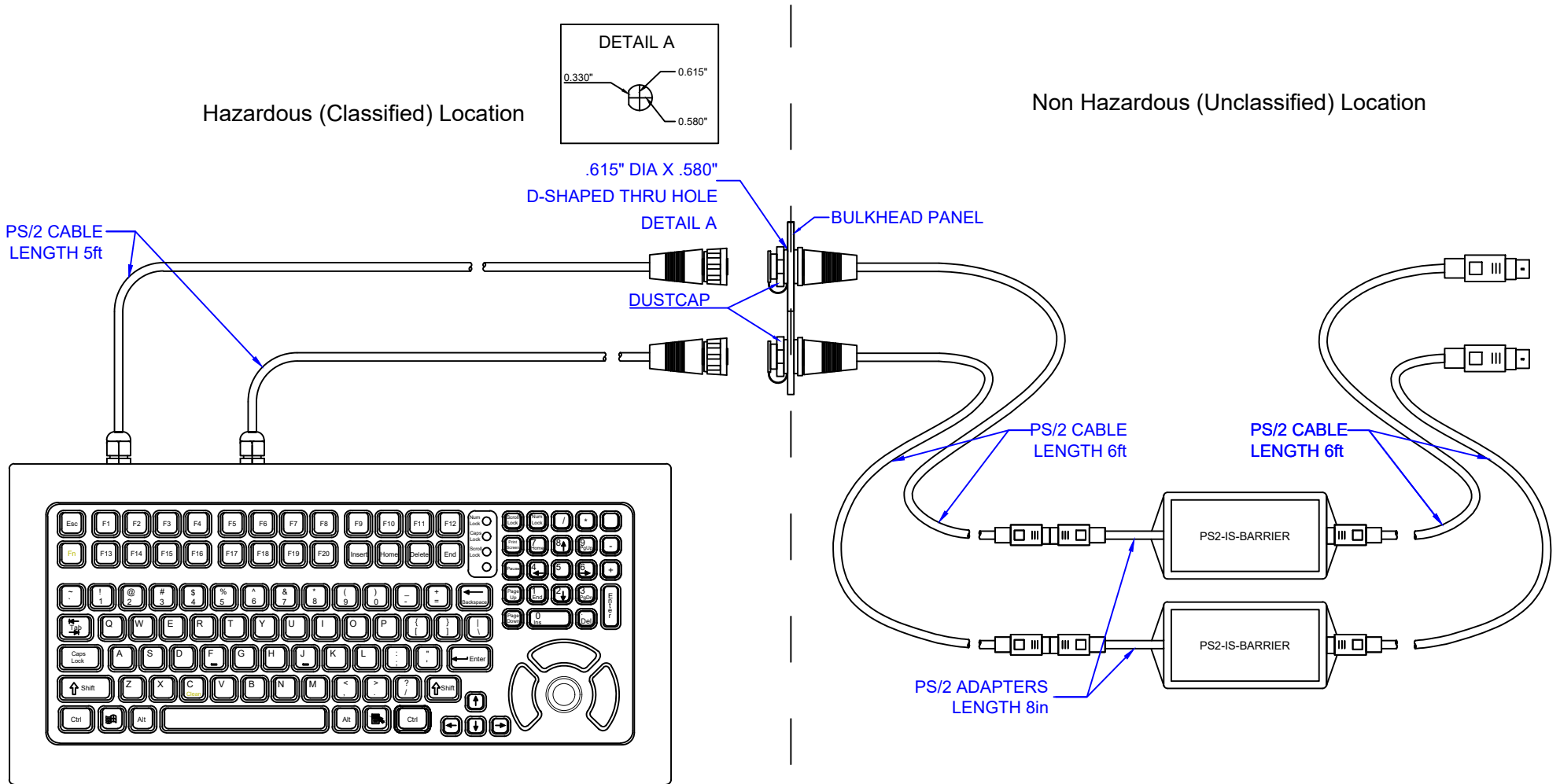

No revision to drawing w/o prior FM approval